

3DViewStation Tutorial

Best Practice



The software programs described in this document and the information contained in this document are confidential and proprietary products of KISTERS or its licensors. KISTERS waives copyright for licensed software users to print out parts of the documentation in hard copy for their own use only. This documentation may not be transferred, disclosed, or otherwise provided to third parties. In duplicating any part of this document, the recipient agrees to make every reasonable effort to prevent the unauthorized use and distribution of the proprietary information.

No parts of this work may be reproduced in any form or by any means - graphic, electronic, or mechanical, including photocopying, recording, taping, or information storage and retrieval systems - without the written permission of the publisher.

KISTERS reserves the right to make changes in specifications and other information contained in this publication without prior notice.

KISTERS makes no warranty of any kind with regard to this material including, but not limited to, the implied warranties or merchantability and fitness for a particular purpose.

KISTERS shall not be liable for any incidental, indirect, special or consequential damages whatsoever (including but not limited to lost profits) arising out of or related to this documentation, the information contained in it or from the use of programs and source code that may accompany it, even if KISTERS has been advised of the possibility of such damages.

Any errors found in any KISTERS product should be reported to KISTERS where every effort will be made to quickly resolve the problem.

Products that are referred to in this document may be either trademarks and/or registered trademarks of the respective owners. The publisher and the author make no claim to these trademarks.

Copyright 2026 KISTERS
Internet: viewer.kisters.de
E-mail: support-viewer@kisters.de
Phone: +49 (0) 2408 9385-360

Author: KISTERS
Date of print of current edition: 13.03.2026
Current software version: Latest

The logo for KISTERS, featuring a stylized 'K' symbol followed by the word 'KISTERS' in a bold, sans-serif font.

Table of Contents

Part I	Basic Operation	5
1.1	User Interface Concept	7
1.2	New User Interface Concept 2025	8
1.3	Customizing the Interface	10
1.4	Quick Access Toolbar	13
1.5	Keyboard Functions (Default Assignment)	14
1.6	Opening a CAD File - Import Settings	15
1.7	Settings	18
1.8	Profiles	19
1.9	Operation with Touch Gestures	20
Part II	3D Data Analysis and Editing Functions	21
2.1	Model Orientation	22
2.2	Flythrough mode	23
2.3	Object Selection	23
2.4	Saving Selections	24
2.5	View and Edit Properties of Selected Objects	25
2.6	Selection modes	27
2.7	Apply Functions to a Selection or to All Objects	29
2.8	Ghost Mode	29
2.9	Neighborhood Search	30
2.10	Customizing the View	32
2.11	Views	33
2.12	Measurement	34
2.12.1	General Settings	34
2.12.2	Point Coordinate	35
2.12.3	Length	36
2.12.4	Circle	36
2.12.5	Distance	37
2.12.6	Angle	38
2.12.7	Face	39
2.12.8	Wall Thickness	39
2.12.9	Bounding Box	39
2.12.10	Drill Hole	39
2.13	Section	40
2.14	Comparison of parts, assemblies and drawings (3D and 2D)	41
2.15	Structure Compare	42
2.16	Projected Area	45
2.17	Neutral Axis, calculate straight length	45

2.18	Draft	47
2.19	Wall Thickness	47
2.20	Clash Detection	52
2.21	Band Analysis	53
2.22	Curvature Analysis	57
2.23	Transformations (Move, Rotate, Mirror and Explode)	62
2.24	Annotations / Markups	72
2.25	Search (Filter)	73
2.26	Technical Documentation (TechDoc) and Bill of Material (BOM)	74
2.26.1	Create bill of material	74
2.26.2	Callouts	78
2.27	Generate, Copy and Move Nodes	82
2.28	Reload Nodes	82
2.29	Node Retessellation	83
2.30	Generate Coordinate System	84
2.31	Generate Auxiliary Geometries	85
2.32	Font substitution (2D)	89
2.33	Attribute CSV import	94
Part III	Export and Print	96
3.1	Save, Save as (Export)	97
3.2	2D Export (Screenshot)	97
3.3	Export Settings	98
3.4	3D-PDF Export with templates	99
3.5	Print	104
Part IV	Miscellaneous	105
4.1	3Dconnexion 3D Mouse	106



Chapter I:

Basic Operation



1 Basic Operation

Click the  desktop icon or go to **START > PROGRAMS > KISTERS > 3DVIEWSTATION** to initiate 3DViewStation.

The application home screen will look as follows (in this example: with the tool **BILL OF MATERIAL (BOM)** enabled):

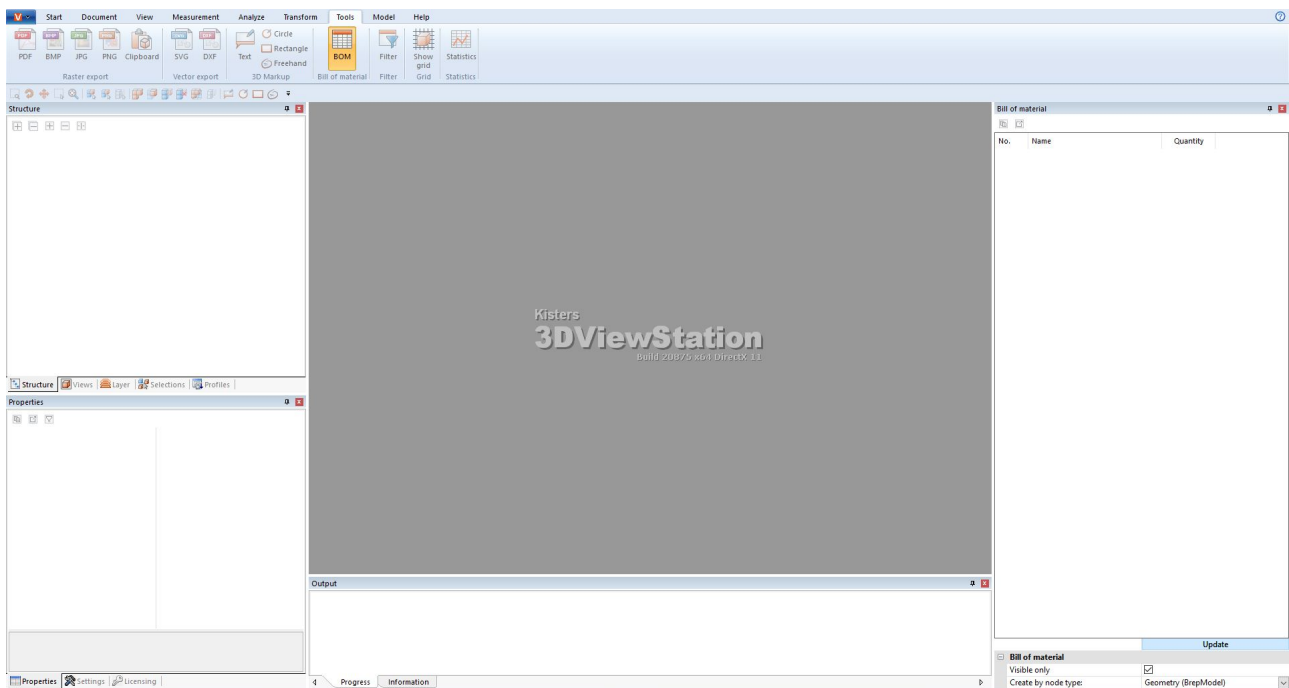

- [User Interface Concept](#) | 7
- [New User Interface Concept 2025](#) | 8
- [Customizing the Interface](#) | 10
- [Quick Access Toolbar](#) | 13
- [Keyboard Functions \(Default Assignment\)](#) | 14
- [Opening a CAD File - Import Settings](#) | 15
- [Settings](#) | 18
- [Profiles](#) | 19
- [Operation with Touch Gestures](#) | 20

1.1 User Interface Concept

The 3DViewStation UI is divided into the following areas (here with the tool **BILL OF MATERIAL (BOM)** enabled):

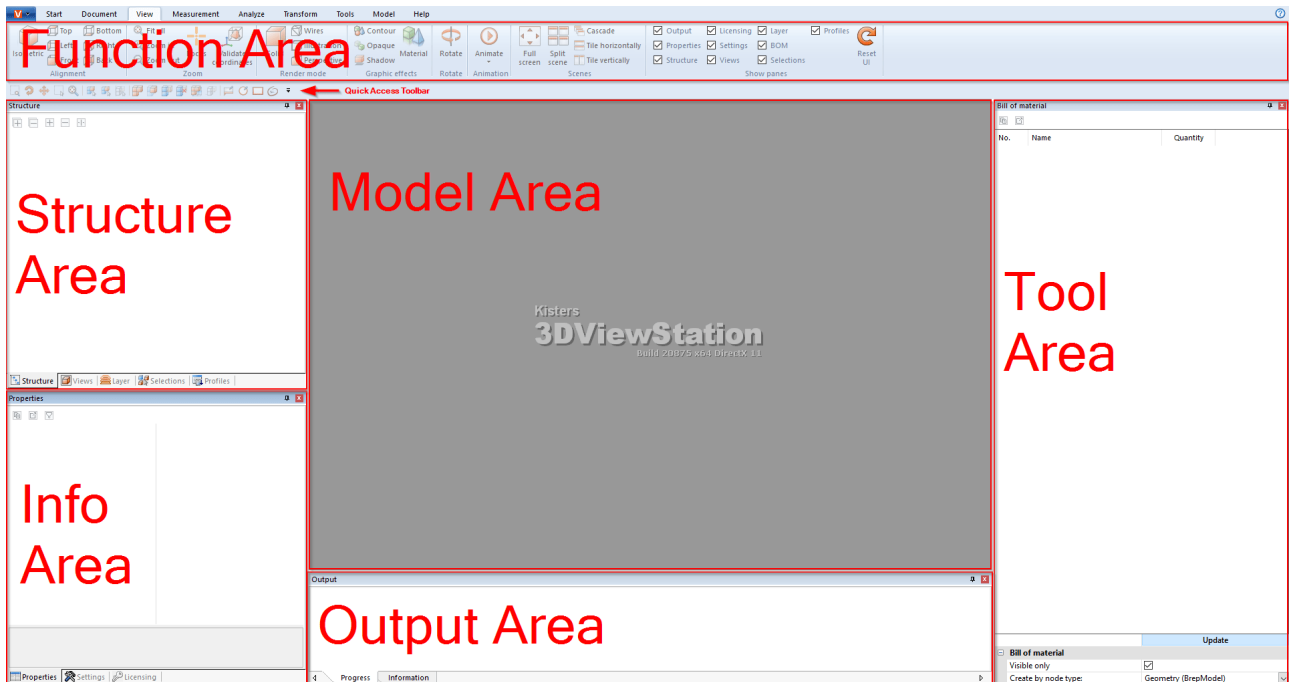

Section	Description
Output Area	The output area displays information about the loading process of models, for example.
Function Area	Here you will find all operating functions of the 3DViewStation grouped on topic-related tabs.
Info Area	There are three sub-panes available in the info area: <ul style="list-style-type: none"> ▪ PROPERTIES: Displays context related properties for the currently selected objects and options to edit these. ▪ SETTINGS: Contains all configuration parameters of the 3DViewStation, sorted by profile, import, export and program settings ▪ LICENSING: Displays licensing information and offers the option for activation via an activation key, and a license checkout option for specific time periods in case of network licenses (see chapter Installation and Licensing).
Model Area	This main area displays the 3D geometry data of the actual loaded model (part or assembly).
Quick Access Toolbar	Among other things, this bar offers quick access to selected functions. The function selection can be adjusted via the last icon on the right (see chapter Quick Access Toolbar ¹³).
Structure Area	Inside point structure of the loaded model is displayed in this area. The current model area can be saved and restored in the view pane (see chapter Views ³³).
Tool Area	This area displays function specific sub-panes (e.g. for measuring or cutting).
Help Box	Helpful information is displayed in the lower part of the relevant sub pane whenever you click menu items or some of the buttons. <div data-bbox="414 1108 1173 1814" style="border: 1px solid gray; padding: 5px; margin-top: 10px;"> <p>Measurement</p> <p>Result Length 0.0 mm</p> <p>Dimensioning</p> <p>General</p> <p>Create dimensioning <input type="checkbox"/></p> <p>Show unit <input checked="" type="checkbox"/></p> <p>Floating format precision 2</p> <p>Unit Millimeter</p> <p>Plane to axis X</p> <p>Display options</p> <p>Allow scaling <input type="checkbox"/></p> <p>Align to screen <input checked="" type="checkbox"/></p> <p>Always on top <input checked="" type="checkbox"/></p> <p>Show frame <input checked="" type="checkbox"/></p> <p>Show background color <input checked="" type="checkbox"/></p> <p>Text settings</p> <p>Node name as content <input checked="" type="checkbox"/></p> <p>Content Note</p> <p>Font Arial</p> <p>Font size 12</p> <p>Color</p> <p>Line color #C00000</p> <p>Frame color #C00000</p> <p>Text color #000000</p> <p>Background color #FFFFFF</p> <p>Create dimensioning Creates dimensionings for measurements with the settings below.</p> </div>

1.2 New User Interface Concept 2025

Since 2025 we've re-arranged the functions and icons in the ribbon to streamline your workflow, improve navigation, and enhance overall efficiency. In the screenshots below, you'll see a clear comparison between the old and new layouts along with helpful hints to guide you through the updated interface.

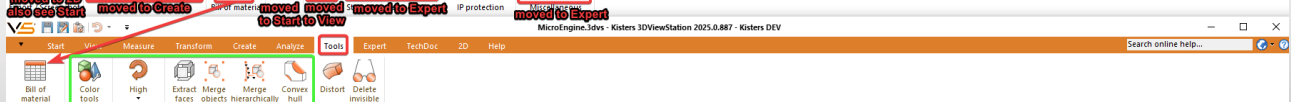
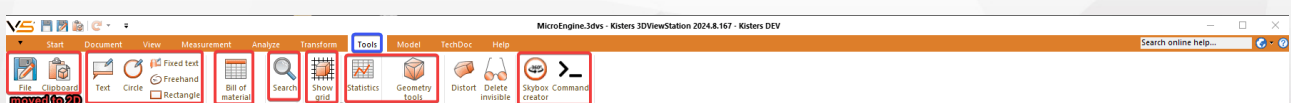
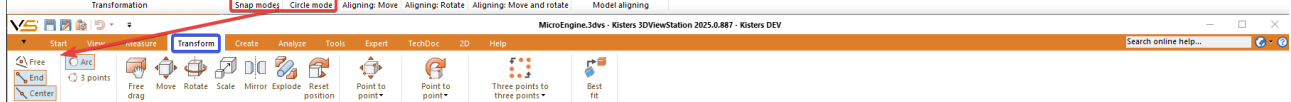
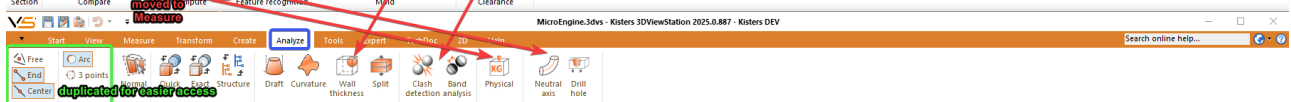
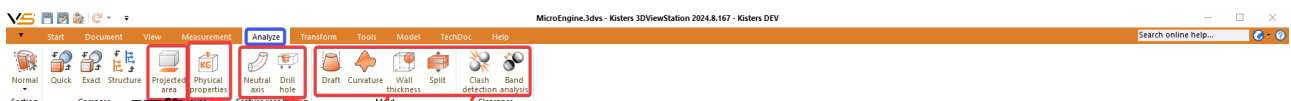
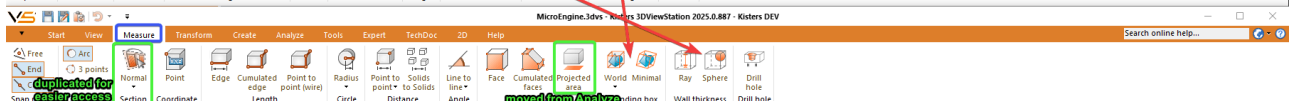
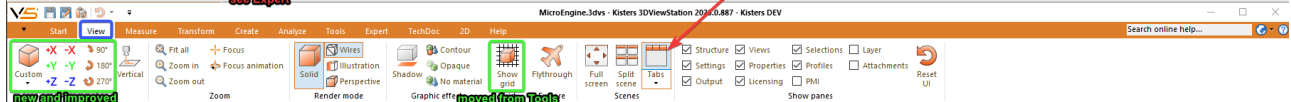
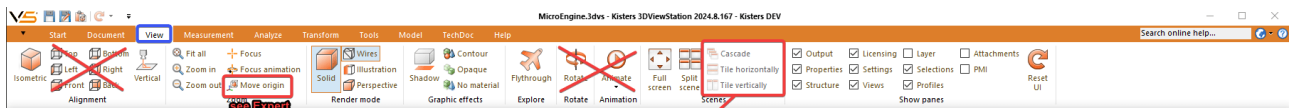
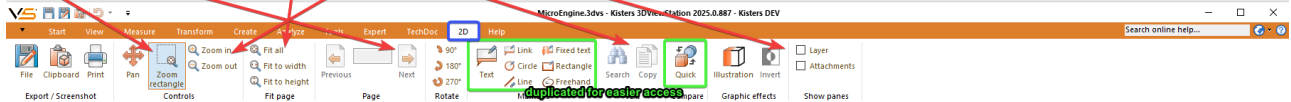
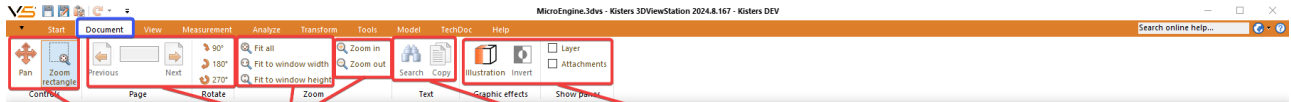
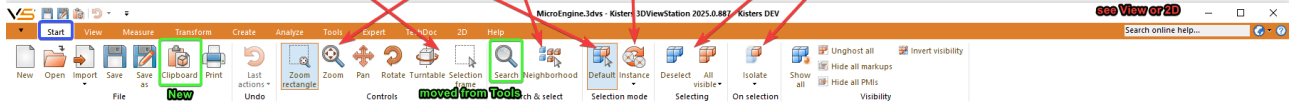

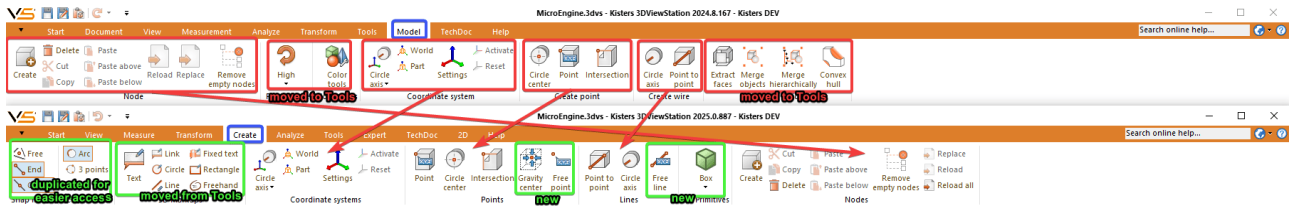



1.3 Customizing the Interface

All sub panes can be repositioned and grouped to suit your requirements by dragging the relevant top bar. When working with two screens, for example, you can use one screen for displaying the model and the other for displaying the various panes containing the functions you need.

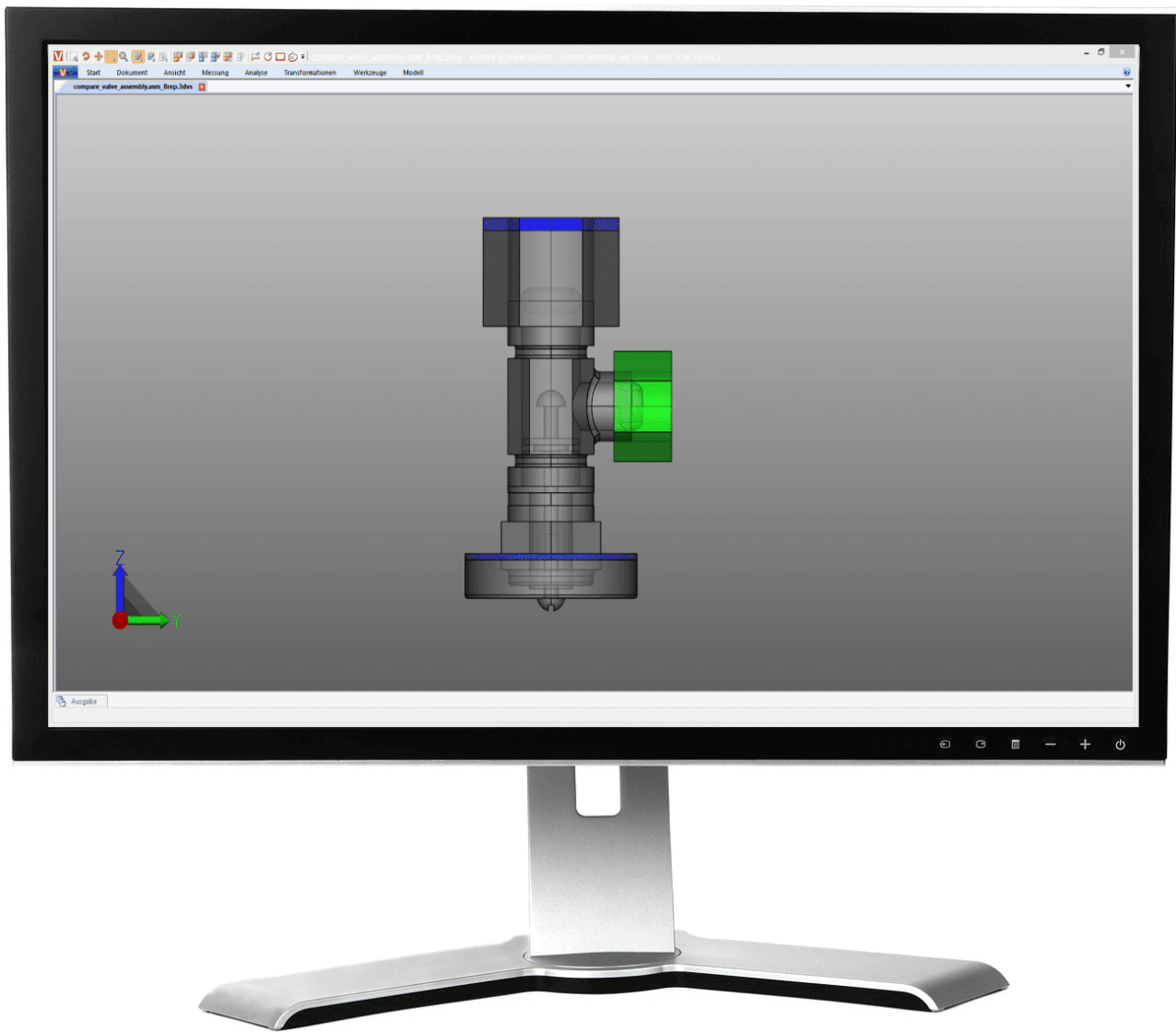
By right clicking on the function area and selecting the **MINIMIZE THE RIBBON** context menu option, you can minimize it.

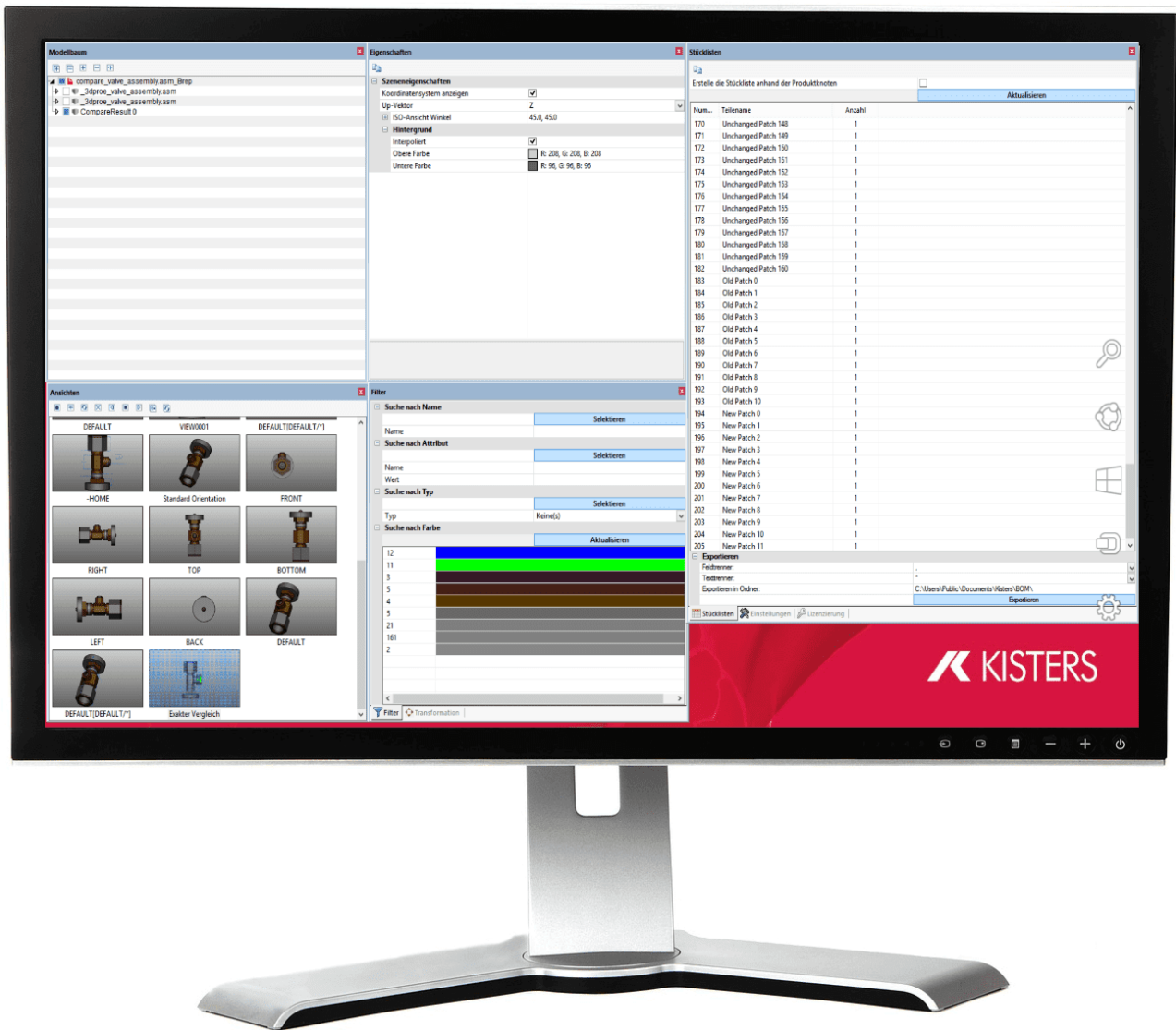



Dragging a sub-pane onto one of the auxiliary objects displayed (e.g.  or ) allows a positioning relative to other sub-panes:

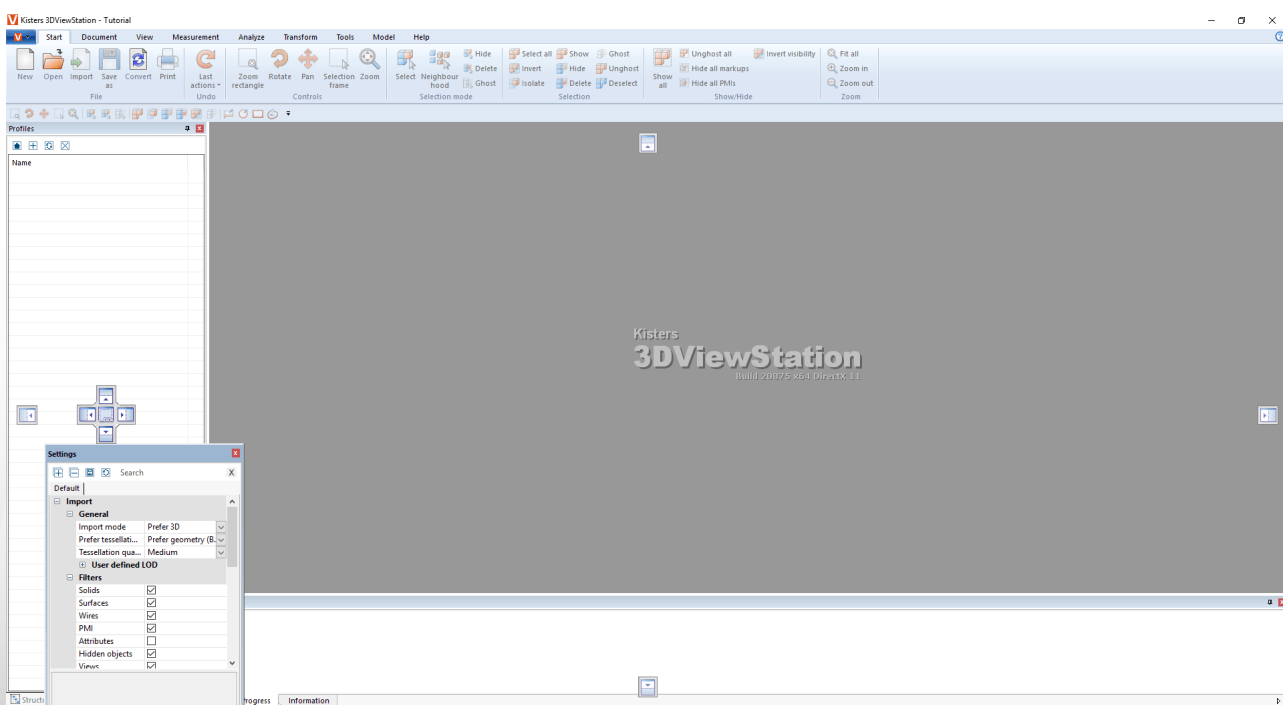

- **Please note** when grouping sub panes (📄) that some panes (Properties or Tools) will be moved to the foreground when a function is selected in the model or activated. This may consequently cover one or more panes of the group.
- All user interface elements are returned to their original state via the button **RESET UI** (🔄) in the **VIEW** tab (this will require a restart of 3DViewStation).
- In the area **SHOW PANES**, you have the option to hide or show unneeded panes.

1.4 Quick Access Toolbar

Frequently used functions can be placed in this toolbar for quick access. All functions available on all tabs can be selected for placement in this bar.

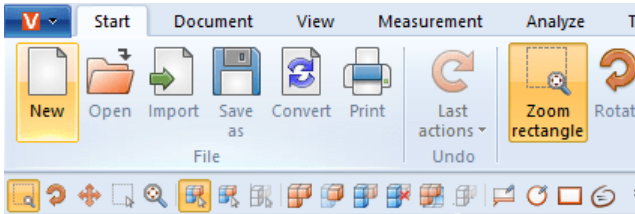

Click the black icon on the very right to open the following selection:

Function	Description
OPEN FILE	Adds the OPEN function to the quick access toolbar.
SAVE AS	Adds the SAVE AS function to the quick access toolbar.
MORE COMMANDS	Opens the CUSTOMIZE pane (see below).
SHOW ABOVE THE RIBBON	Repositions the quick access toolbar into the ribbon of the 3DVIEWSTATION pane.
MINIMIZE THE RIBBON	Minimizes the function area and shows the functions only when you click in the function area.

To customize the quick access toolbar,

- open the **CUSTOMIZE** pane by choosing **MORE COMMANDS**.

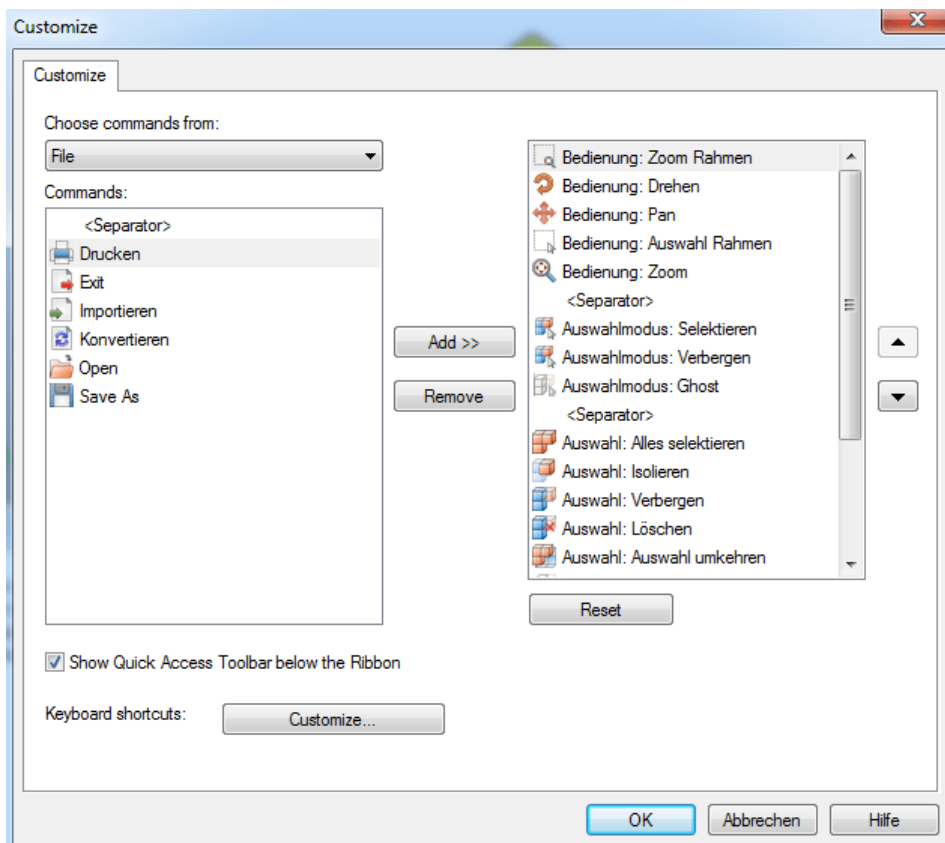

The function areas of the 3DViewStation can be found under **CHOOSE COMMANDS FROM**.

- Select the area from which you want to add functions to the quick access toolbar.
- The corresponding functions are displayed under **COMMANDS**.
- In the left pane, select the function to be added and click **[ADD]**.
- Highlight the function to be moved in the pane on the right and click one of the arrows on the right edge of the pane.
- Click **[REMOVE]** to delete a selected function in the right pane from the quick access toolbar.

Tip: To add a function to the Quick Access Toolbar, right click on it and select **ADD TO QUICK ACCESS TOOLBAR**.

1.5 Keyboard Functions (Default Assignment)

The following keyboard functions are set by default:

Keyboard functions	Function
[CTRL]	Additive selection or deselection of elements
[ESC]	Ending the current function and activating the select mode
[⇧]	Selection or deselection of elements by areas
[ALT]+[G]	Ghosting for objects under the cursor
[ALT]+[S]	Displays ghosting in reverse order
[ALT]+[H]	Hide objects

Keyboard functions	Function
[ALT]+[A]	Restore hide
[ALT]+[I]	Isolate selection
[CTRL]+[A]	Select all
[CTRL]+ [⇧]+[A]	Deselect all
[CTRL]+[I]	Invert selection
[CTRL]+[C]	Copy objects
[CTRL]+[V]	Insert copied objects
[CTRL]+[U]	Show grid on/off
[CTRL]+[Z]	Undo last operation
[F1]	Show Help tutorial
[F5]	Zoom Fit
[F9]	Tessellation on/off
[F11]	Full-screen mode on/off

The keyboard commands can be added to and adapted as needed. Simply open the **CUSTOMIZE** pane in the **quick access toolbar**  and click **KEYBOARD SHORTCUTS: [CUSTOMIZE]**.

Note: [F1] and [F11] cannot be reassigned.

1.6 Opening a CAD File - Import Settings

The function **OPEN** in the **START** tab opens a file selection dialog, via which you can select the relevant file. If one or more models are already loaded, additional models can be imported into the active model area by selecting the **IMPORT** function.

Alternatively, a file can be moved via Drag-and-Drop from e.g. Windows File Explorer to the function area to open the model in a new tab or to the active model area for model import.

The settings to be used for importing or opening the CAD file(s) can be set in the Info area in the **SETTINGS** sub pane within the **IMPORT** area:

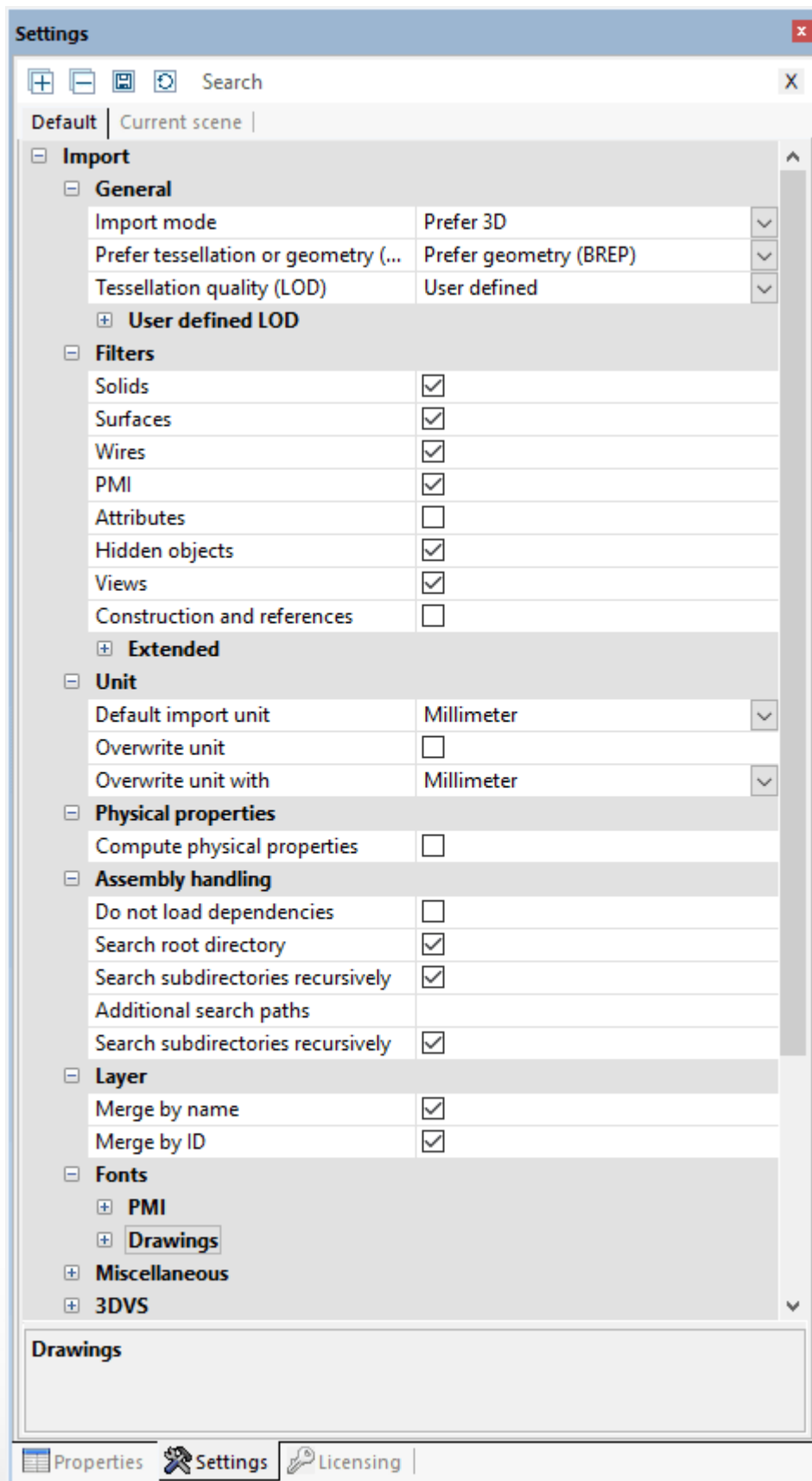

General

The setting **TESSELLATION** or **PREFER GEOMETRY (BREP)** specifies, whether an existing tessellated representation should be used when loading CAD models or whether a new tessellation should be calculated on the basis of the geometric information (BREP). The visual quality (mesh count) is specified via the setting **TESSELLATION QUALITY**

(LOD). This setting will not be used if the read mode **PREFER TESSELLATION** was selected. Additionally, when **PREFER TESSELLATION** is selected and the models to be loaded do not contain tessellated data, the geometry (BREP) information is automatically used - and vice versa.

This setting will have the following effects:

- If the CAD models to be loaded include tessellated representations (e.g. CATIA V5 CGR), then these can be loaded faster in **PREFER TESSELLATION** mode than by having 3DViewStation carry out the calculations. The tessellation shown will then match the view within the originating CAD system.
- When models are loaded to convert them to another format (e.g. STEP), the quality of the tessellation can be influenced by the read mode **PREFER GEOMETRY (BREP)**. This setting furthermore influences the file size of formats containing tessellation information, e.g. 3DVS, JT, STL or VRML.

Further information on tessellation quality can be found in the chapter [Node Retessellation](#) .

General Settings

Here you specify the object type to be loaded. Any **HIDDEN OBJECTS** loaded will remain hidden, but can be unhidden via the model tree or by right clicking **SHOW ALL**.

Advanced settings

In the settings under **PHYSICAL PROPERTIES** you can, among other things, calculate the density of the model with very high precision (in **GEOMETRY** read mode) during import. Depending on the size of the model, this may incur extended load times. That is why you can choose to calculate the physical properties for a selection later, when you actually need them. Use the **PHYSICAL PROPERTIES** button in the **ANALYZE** tab to do this. In that case, precision will depend on the configured tessellation quality. Where models containing tessellation only are calculated during import, the quality will depend on that tessellation.

1.7 Settings

The 3DViewStation settings can be found in the Info area at the bottom left of the interface. This pane will only contain the tab **DEFAULT** if no model is loaded as yet. Once a model is loaded, the tab **CURRENT SCENE** is also displayed here.

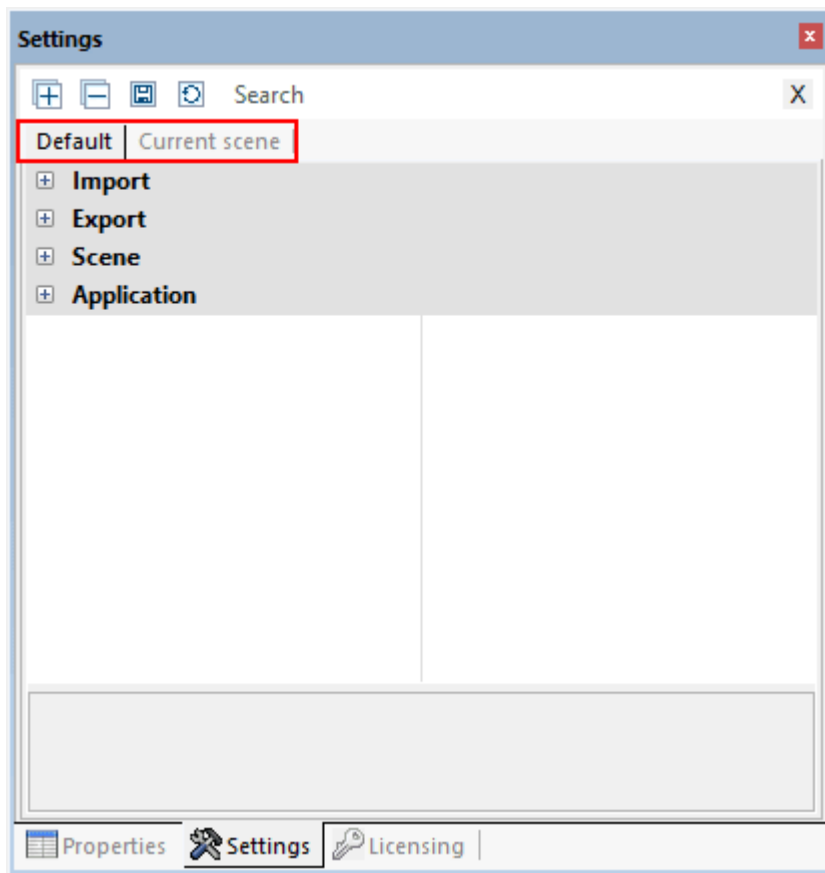

- The settings of the **DEFAULT** tab correspond to the default settings when 3DViewStation is launched for the first time.
- You can configure your custom settings here if you want to change your default settings permanently, e.g. the number of decimal places, choosing another background or changing the tool configurations.
- If a model is loaded so that a 3D or 2D scene will now be available, the additional tab **CURRENT SCENE** will be displayed.
- The settings for the tab **CURRENT SCENE** will initially match those of the tab **DEFAULT > SCENE**. These include tool configurations, settings and visualization options, etc.
- When you modify settings directly from within an activated tool or in the model (of the current scene), then these changes correspond to the settings in the tab **CURRENT SCENE**.

Note: Changes in the model or the current scene are temporary and therefore not saved by default. You receive a notification message that allows you to transfer the temporary settings to the default settings.

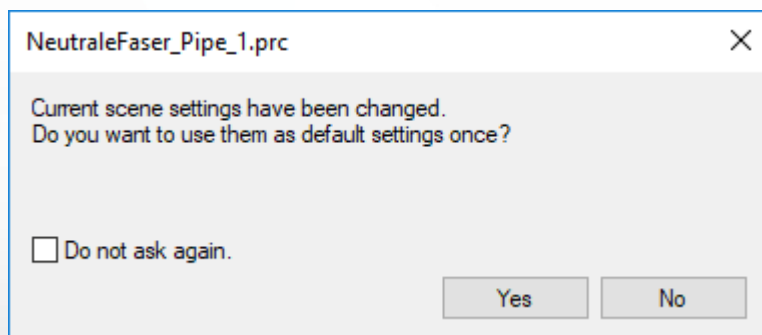

- If several models are open, the settings in the tab **CURRENT SCENE** always correspond to those of the model currently visible (current scene). You can therefore test and change settings in the model without having to fear any negative repercussions on future tasks or concurrently opened models.

- Clicking the button  will revert the settings changed by a profile back to the default settings before the profile was activated.
- The default settings changed by the profile will be saved upon exiting. You will now work with these profile settings permanently, unless other changes are made later. To prevent this, you can deactivate the **SAVE SETTINGS** function. The default settings will be the same each time 3DViewStation is relaunched.
- For further administrative options, e.g. software distribution, please refer to our Licensing and Installation manual or contact our [Support](#).

1.9 Operation with Touch Gestures



This functionality is available **from version 2024.8**.

On a suitable device, you can operate 3DViewStation using other Windows touch gestures in addition to normal tapping on the touch surface. Below are some basic examples:

Function	Gesture	Demonstration
Move	<ul style="list-style-type: none"> ▪ Touch the touch surface with two fingers at the same time. ▪ Move both fingers back and forth evenly while touching the touch surface. 	The demonstration videos are available in the Helpcentre .
Zoom in/out (pinch-to-zoom)	<ul style="list-style-type: none"> ▪ Place two fingers next to each other on the touch surface. ▪ Zoom in: Move your fingers away from each other while touching the touch surface. ▪ Zoom out: Move your fingers towards each other while touching the touch surface. 	The demonstration videos are available in the Helpcentre .
Rotate	<ul style="list-style-type: none"> ▪ Touch the touch surface with two fingers in succession. ▪ Move both fingers back and forth evenly while touching the touch surface. 	The demonstration videos are available in the Helpcentre .
Right-click (press and hold)	<ul style="list-style-type: none"> ▪ Touch the touch surface with one finger and then hold your finger in this position. ▪ This opens the context menu. This gesture corresponds to a right-click with the mouse. 	The demonstration videos are available in the Helpcentre .



To be able to use the touch gestures, the following system requirements apply:

- Devices with multi-touch support (touchpad/touchscreen)
- Windows 10
- 4 GB RAM
- 32 GB hard drive space



Chapter II:

3D Data Analysis and Editing Functions



2 3D Data Analysis and Editing Functions

In this chapter, you will find detailed descriptions of these functions:

- Model Orientation [22](#)
- Flythrough mode [23](#)
- Object Selection [23](#)
- Saving Selections [24](#)
- View and Edit Properties of Selected Objects [25](#)
- Selection modes [27](#)
- Apply Functions to a Selection or to All Objects [29](#)
- Ghost Mode [29](#)
- Neighborhood Search [30](#)
- Customizing the View [32](#)
- Views [33](#)
- Measurement [34](#)
- Section [40](#)
- Comparison of parts, assemblies and drawings (3D and 2D) [41](#)
- Structure Compare [42](#)
- Projected Area [45](#)
- Neutral Axis, calculate straight length [45](#)
- Draft [47](#)
- Wall Thickness [47](#)
- Clash Detection [52](#)
- Band Analysis [53](#)
- Curvature Analysis [57](#)
- Transformations (Move, Rotate, Mirror and Explode) [62](#)
- Annotations / Markups [72](#)
- Search (Filter) [73](#)
- Technical Documentation (TechDoc) and Bill of Material (BOM) [74](#)
- Generate, Copy and Move Nodes [82](#)
- Reload Nodes [82](#)
- Node Retessellation [83](#)
- Generate Coordinate System [84](#)
- Generate Auxiliary Geometries [85](#)
- Font substitution (2D) [89](#)
- Attribute CSV import [94](#)

2.1 Model Orientation

Various functions are available for orienting the model. After opening a model, the two functions **ZOOM RECTANGLE** and **SELECT** are activated by default. You control both functions using the left mouse button.

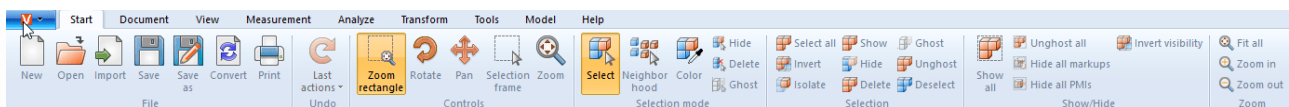

The **Select** [23](#) function is executed by clicking the left mouse button. You can change the function by clicking on the left mouse button in the **START** tab > **SELECTION MODE**, for example.

The zoom rectangle, which is activated as well, can also be controlled with the left mouse button: If you hold down the left mouse button, you can draw a frame in the model window. This function allows you to adapt the display area to the content of the frame. The function with pressed left mouse button can be changed in the **START** > **OPERATION** tab.

The model area is adjusted to the display of all objects by double clicking in an empty area of the model pane or via **ZOOM** in combination with the function **FIT**.

Turning the mouse wheel or using the function **ZOOM IN** or **ZOOM OUT** will increase or reduce the display size.

Clicking and holding the right mouse button while moving the mouse within the model area will rotate the view. The virtual camera is moved around the model, while the model remains static. The rotation point is located either along the center line of the model or (with the right mouse button clicked on a particular spot of the model) along the cursor line. This rotation point is visualized with a cross.

A single right click of the mouse opens the context menu and allows quick access to frequently used functions, which will be explained in more detail in the coming chapters.

By pressing both mouse buttons or the middle mouse button (mouse wheel) and simultaneously moving the cursor, the view of the model can be moved.

You can change more mouse settings and pre-assignments via **SETTINGS > DEFAULT > SCENE > MOUSE** (see also chapter [Settings](#)^[18]).

More options for the orientation and visualization of the model are described in chapter [Customizing the View](#)^[32].

2.2 Flythrough mode

With the flythrough mode you can fly through any geometry with the camera, for example to measure the inside of buildings or to gain an impression of the object's proportions.

The **FLY THROUGH** function can be found under the menu item **VIEW > EXPLORE**.

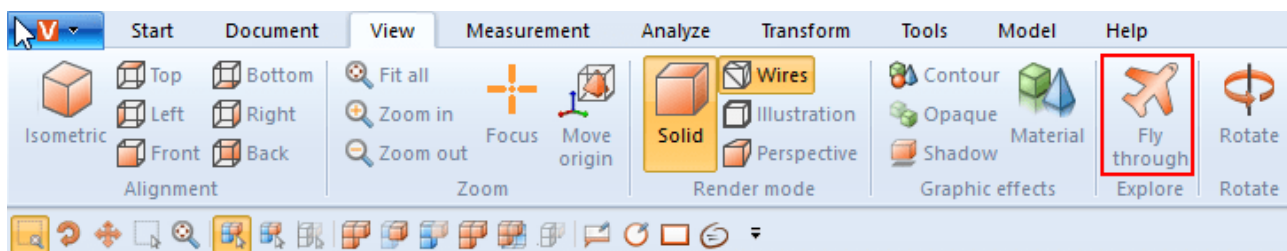

When activating the flythrough mode, the render mode **PERSPECTIVE** is activated first (see also chapter [Customizing the View](#)^[32]). Due to the required perspective representation, the distance to the geometry is first adjusted. To avoid large jumps of the camera, the perspective can be activated first under **VIEW RENDER MODE**. At the same time, the up vector (defines the top orientation) is set according to the value set under **CAMERA UP VECTOR** and remains constant for the course of the flythrough mode in order to prevent the camera from being tilted.

Controls

The camera can be moved using a keyboard, mouse or 3Dconnexion 3D mouse.

- Use the **[W]** / **[A]** / **[S]** / **[D]** keys or the arrow keys to move the camera forward or sideways.
- The **[SPACE BAR]** / **[C]** or the page up and down keys are used for up and down movement.
- By holding down the left or right mouse button without moving the mouse, the camera flies forwards or backwards, whereby the direction of movement of the camera is adjusted by subsequent mouse movements.
- By pressing the right mouse button and moving the mouse, the viewing direction of the camera can be adjusted as usual. The delay for triggering the **FLYING WITH PRESSED MOUSE BUTTON** can be adjusted in the **DELAY WITH PRESSED MOUSE BUTTON** option.
- The **[+]** / **[-]** keys adjust the speed at which the model is flown through.

To obtain information on the individual settings, click on a setting in the tool area. You will then receive detailed descriptions of the respective setting in the lower area of the windows – in the so-called **Help Box**^[8]. When creating [views](#)^[33], the settings made for flythrough mode including camera position are maintained. When leaving the flythrough mode, the camera is reset to the last known position.

2.3 Object Selection

Many advanced tools require a previous selection. Selections are created via the following functions and are saved as described in chapter [Saving Selections](#)^[24].



Individual parts of an assembly can be selected by clicking them directly within the model area or by clicking the corresponding entry in the model structure for more processing steps.

The selection can be cancelled by pressing the **[ESC]** key or by clicking in the background of the model area.

With [CTRL] pressed at the same time, more geometries can be added to the selection. Clicking the selected geometries again will deselect them.

With the [⇧] key pressed at the same time in the model structure, all parts can be selected which are grouped in the structure between the first and the last selected entry.

Clicking an object will initially select the relevant geometry (lowest level in the **STRUCTURE** view). A further click of a previously selected object selects the next higher level of the structure, and so on until the entire model is selected. Another click will then return the selection to the initial geometric element. This enhanced selection can be disabled via **SETTINGS > SCENE > GENERAL**.

You can also choose a Selection frame via **START > CONTROLS**. It can be used by dragging a pane with the left mouse button pressed. The content inside the frame will then be selected.

Please note that all geometries that at least partially lie within the selection frame are selected when the frame is drawn from left to right. Dragging the pane from right to left on the other hand, will only select geometries completely contained within the frame.

All visible geometries can be selected by clicking the [**SELECT ALL**] button or by using the shortcut [CTRL]+[A] in the **SELECTIONS** area.

You will find a description of other options for creating specific selections in the chapters [Neighborhood search](#) and [Filter \(Search\)](#).

2.4 Saving Selections

3DViewStation offers you the possibility to save selected objects of an assembly in selections.

Saving a Selection

- Select one or more objects of an assembly. cf. [Object Selection](#).
- In the [structure area](#), select the **SELECTIONS** tab.
Note: If the Selections tab should be hidden, it can be opened via **VIEW > SHOW PANES > SELECTIONS** can be displayed.
- Click the  symbol.

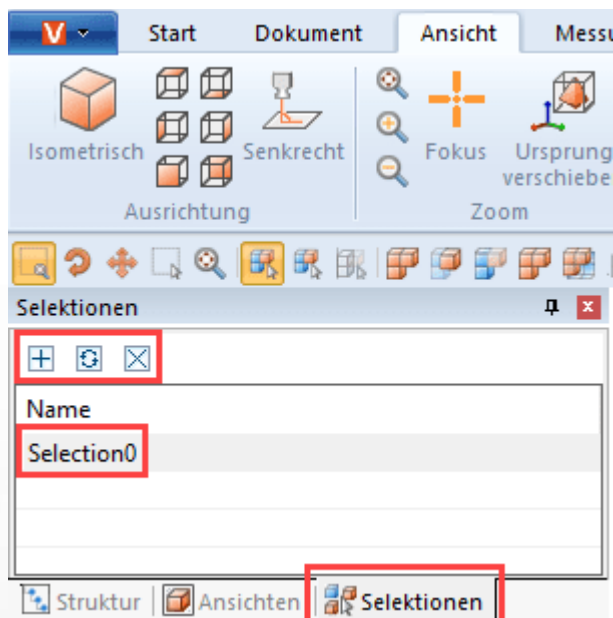

The selection is created as a list entry with the name **SELECTION0**.

Rename selection

- In the structure area, select the **SELECTIONS** tab.
- Select the desired selection from the list entries.
- Click the list entry once more or press the [F2] key to activate the edit mode.

Update selection

- In the structure area, select the **SELECTIONS** tab.
- Select the desired selection from the list entries.
- Select further objects of the assembly while holding down the **[STRG]** key. Re-selecting objects that have already been selected will cancel the selection.
- Click the  icon to update the selection.

Delete selection

- In the structure area, select the **SELECTIONS** tab.
- Select the desired selection from the list entries.
- Click the  icon or press the **[DELETE]** key to delete the selected selection.

Tip

- Just like for the selection of multiple geometries, you can press and hold the **[CTRL]** key at the same time to combine various saved selections.
- Selections are saved with the 3DVS format when saving.

2.5 View and Edit Properties of Selected Objects

Once an object is selected, the sub pane **PROPERTIES** displays the node properties and can be edited there (see first/left image):

Where multiple objects are selected, only those properties will be displayed under **NODE PROPERTIES** that all objects have in common. Otherwise the entry **MISCELLANEOUS** will be displayed (see second/right image):

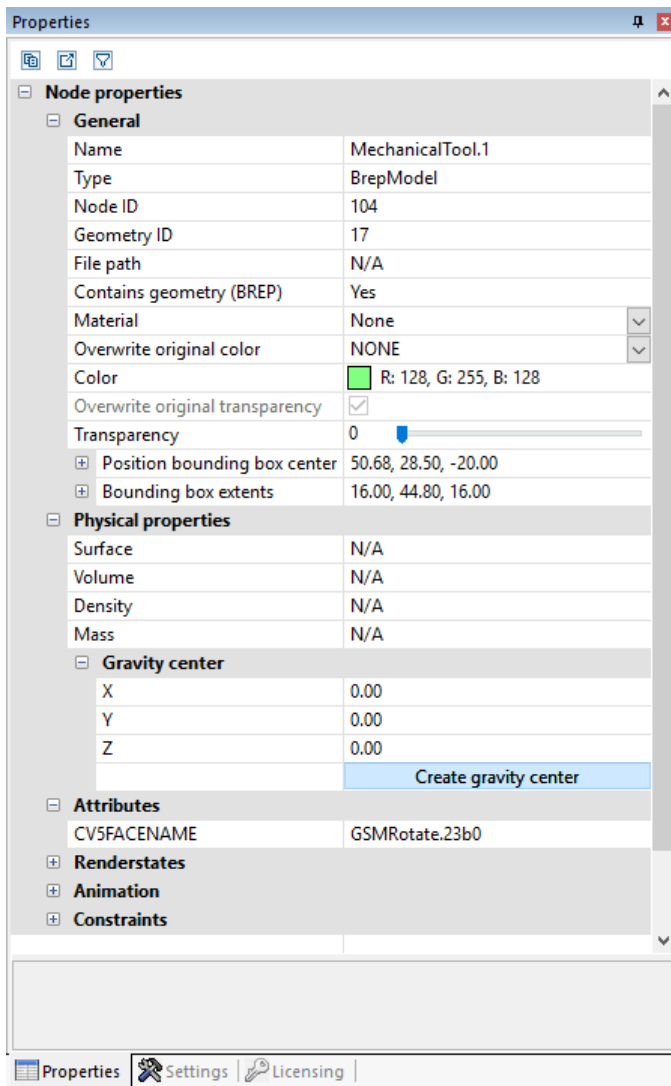

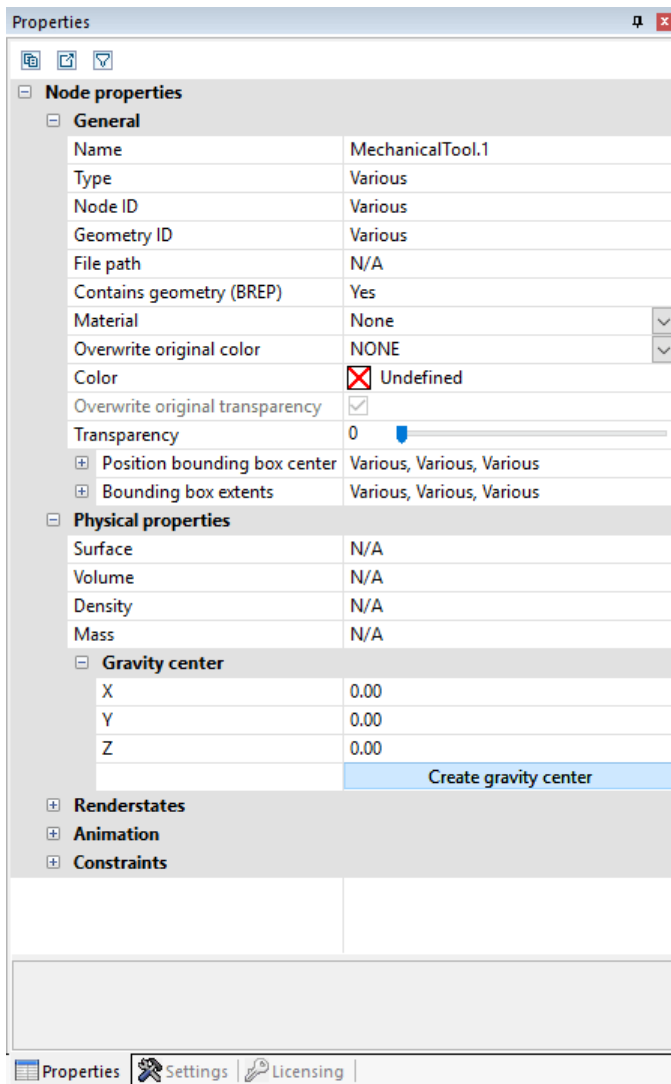

Changes applied to multiple selected objects (e.g. color) for which **MISCELLANEOUS** is displayed, will affect all selected objects.

Clicking the background will deselect an existing selection and displays the properties of the current scene. You can also find these scene properties under **SETTINGS > CURRENT SCENE**, a pre-configuration for new scenes can therefore also be done via **SETTINGS > DEFAULT > SCENE**.

If the **PROPERTIES** pane has been hidden by another pane, creating a selection brings the properties pane to the foreground. This behavior can be deactivated via **SETTINGS > DEFAULT > APPLICATION > UI > ACTIVATE PROPERTIES WINDOW**.

The two buttons at the upper edge of the pane allow the export of the content of some panes and some properties to a CSV file or to copy the content to the Windows clipboard.

2.6 Selection modes

Clicking **HIDE**, **DELETE** or **GHOST** in the **SELECTION MODE** tab of the **START** ribbon will hide (temporary), delete (permanent) or ghost (see chapter [Ghost Mode](#)^[29]) all with the mouse selected objects, until the relevant function is deactivated by pressing **[ESC]** or clicking the **SELECT** function.

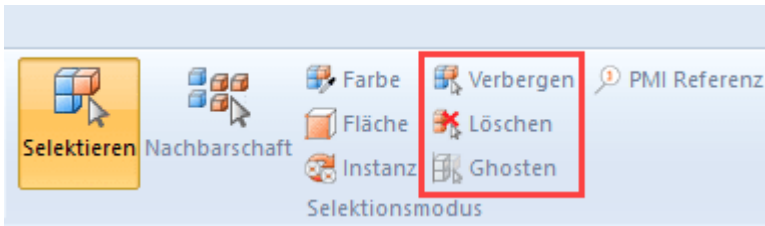

Color

The selection mode **COLOR**, allows you to select all objects of a certain color in an assembly.

Surface

The selection mode **SURFACE**, allows you to select individual surfaces of objects. After selecting a surface, hold down the **[CTRL]** key to select multiple surfaces.

In the **info area**, you can adjust the color and transparency of the selected surfaces in the surface properties.

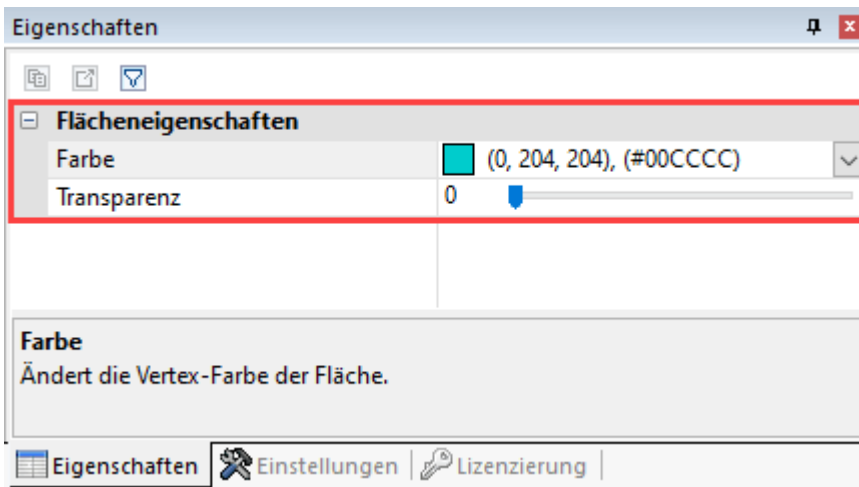

Instance

Identical objects are treated as a single instance by 3DViewStation. You can use the **INSTANCE** selection mode to select these object groups.

- On the **START** tab, in the **SELECTION MODE** area, activate the **INSTANCE** mode.
- Select an object that exists in identical form several times in the assembly.

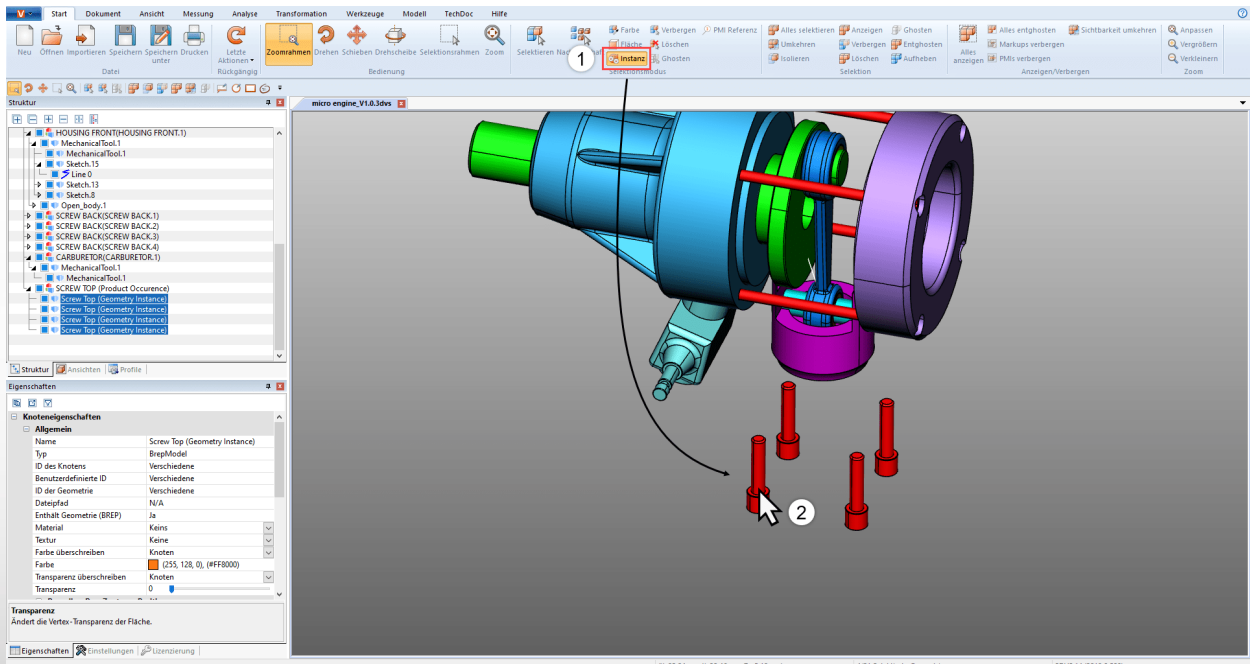

All identical objects that match the original selection will be selected.

PMI Reference

The **PMI REFERENCE** selection mode allows you to display the PMI reference (product manufacturing or design information) that matches a surface.

- On the **START** tab, in the **SELECTION MODE** area, activate the **PMI REFERENCE** mode.
- Select a surface in the model.

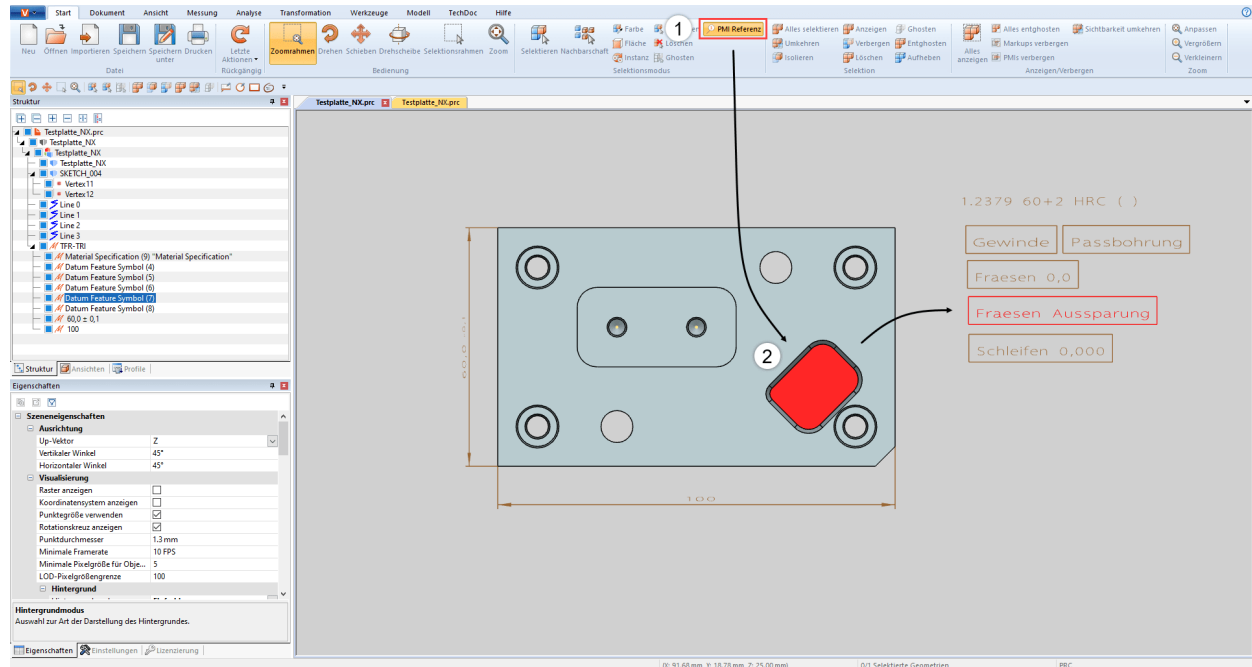

The PMI reference associated with the surface (if it exists) is highlighted in color.

2.7 Apply Functions to a Selection or to All Objects

In addition to the direct selection mode, previously selected objects can also be hidden, isolated or deleted via the respective buttons in the **START > SELECTION** area. The functions in the **SHOW > HIDE** area are always applied to all objects.

Some of these functions can also be accessed via the right-click context menu or via a shortcut.

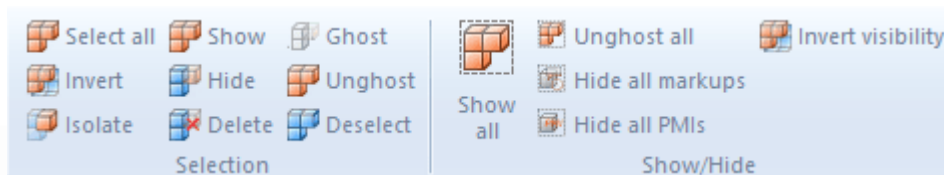

2.8 Ghost Mode

GHOST mode gives parts transparency, but unlike purely transparent geometries, ghosted geometries in the model area can no longer be selected. That means you can select and dimension the part behind the ghosted part. These ghosted geometries are displayed with a grayed out icon in the structure.

Enable the ghosting mode via **START > SELECTION MODE > GHOST** or select the relevant objects and click the button **START > SELECTION > GHOST**. Alternatively you can use the key combination **[ALT]+[G]** to ghost the object at the cursor position (no previous selection required).

To make all ghosted parts visible again, the **UNGHOST** function can be selected in the **SHOW > HIDE** area. The **GHOST** mode is also disabled by selecting the **SHOW ALL** function. The key combination **[ALT]+[S]** will unghost all parts one by one in reverse order. A selective deactivation of the **GHOST** mode is made possible by selecting corresponding geometries in the structure and then selecting the **UNGHOST** option in the **SELECTION** area.

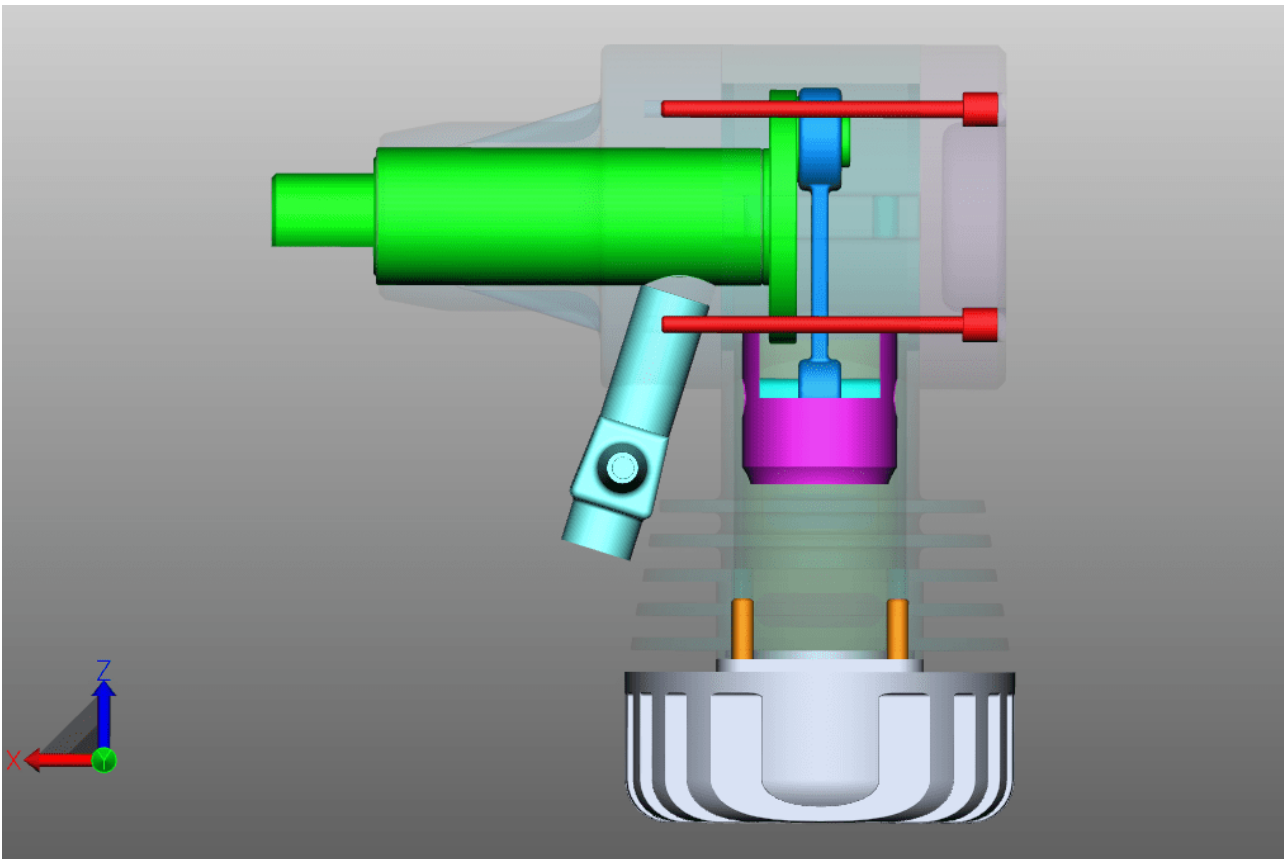

2.9 Neighborhood Search

The neighborhood search finds all geometries whose bounding box intersects the sphere radius specified during the search by the current selection.

Neighborhood search for an object of an assembly

- Initiate the neighborhood search with the **NEIGHBORHOOD** button from the **START** tab in the **SELECTION MODE** area and click on the desired geometry or create a selection. Alternatively, you can first select the geometry and then click the **NEIGHBORHOOD SEARCH** button.
The **NEIGHBORHOOD SEARCH** pane appears in the right-hand tool area, where you can edit the search radius or the search distance. Initially, the dimensions of the Bounding Box of the selected original geometry is used as the search radius.
- Returned geometries can then be selected and/or isolated depending on the desired option. You can also include hidden geometries.
Further information on the individual options of the neighborhood search can be found in the help box of the respective option. See [User Interface Concept](#)

- Start the search by activating the **[COMPUTE]** button.

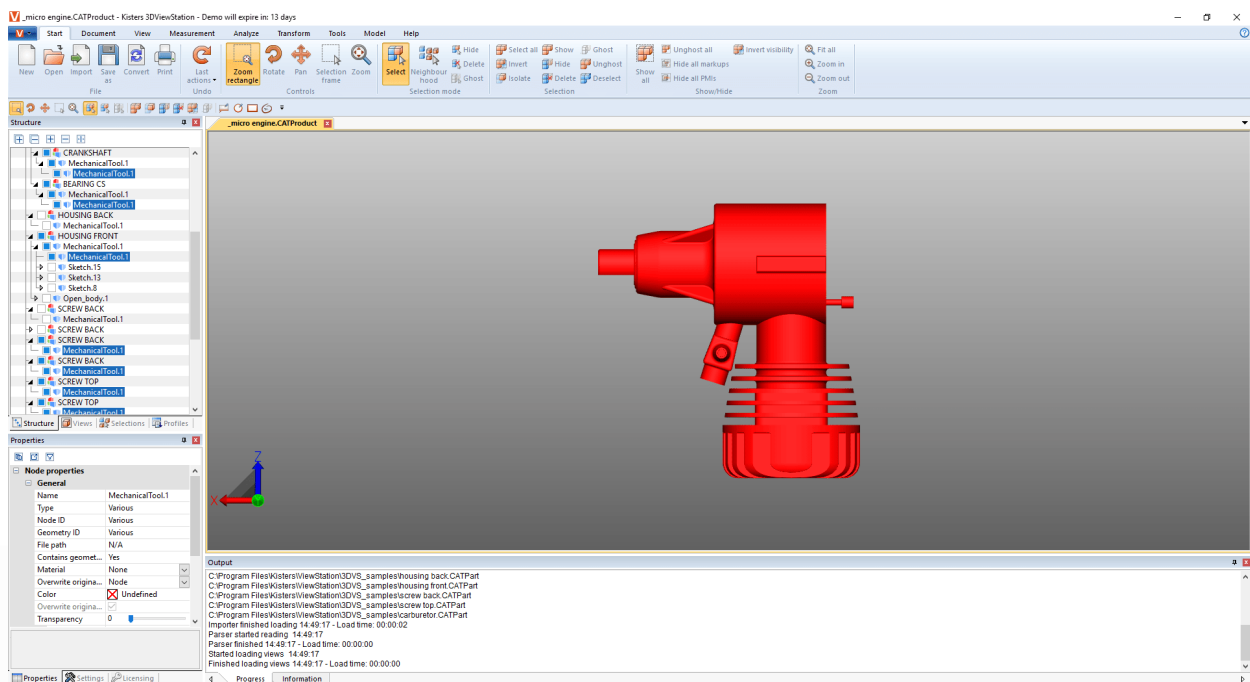
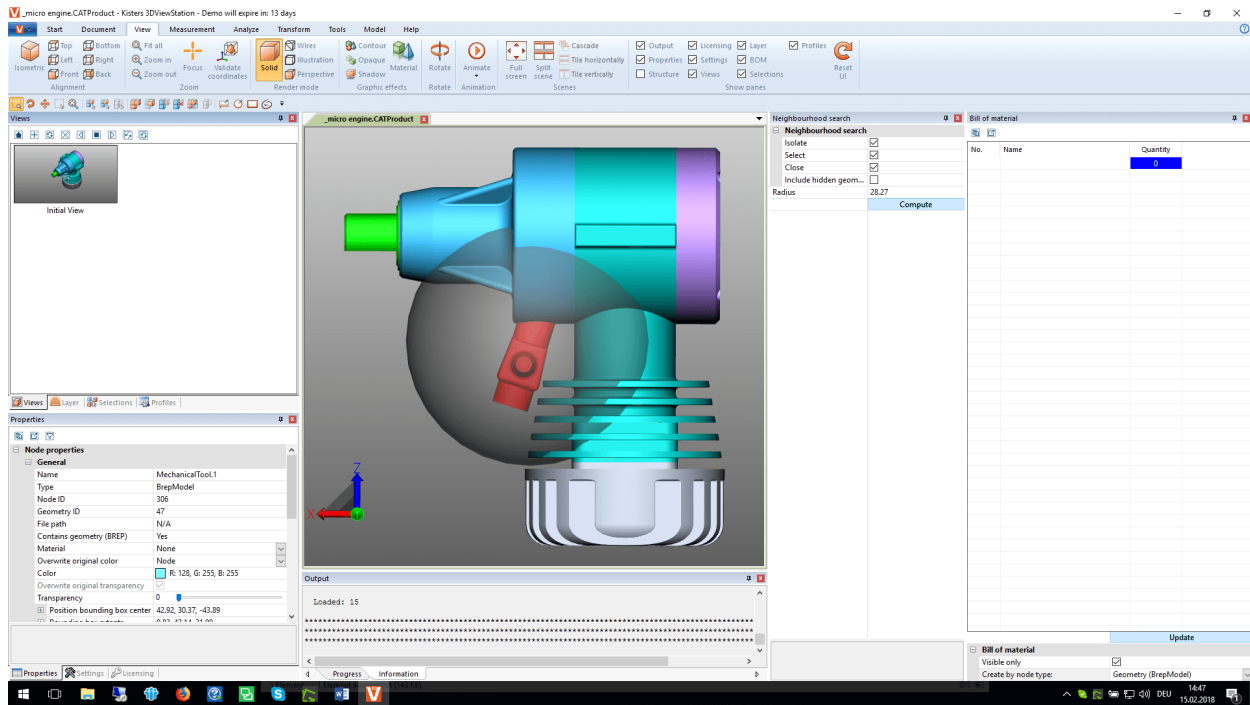

Neighborhood search for multiple objects of an assembly

You can also apply the neighborhood search to several selected objects at the same time.

- Start the neighborhood search with the **NEIGHBORHOOD** button from the **START** tab in the **SELECTION MODE** area.
- Click on a desired object in the assembly.
- While holding down the **[CTRL]** key, click on any number of additional objects in the assembly. See [Object Selection](#) 231
- Step 1: In the Neighborhood Search tool area, adjust the search radius or distance.
- Step 2: Click the **APPLY TO ALL** button.

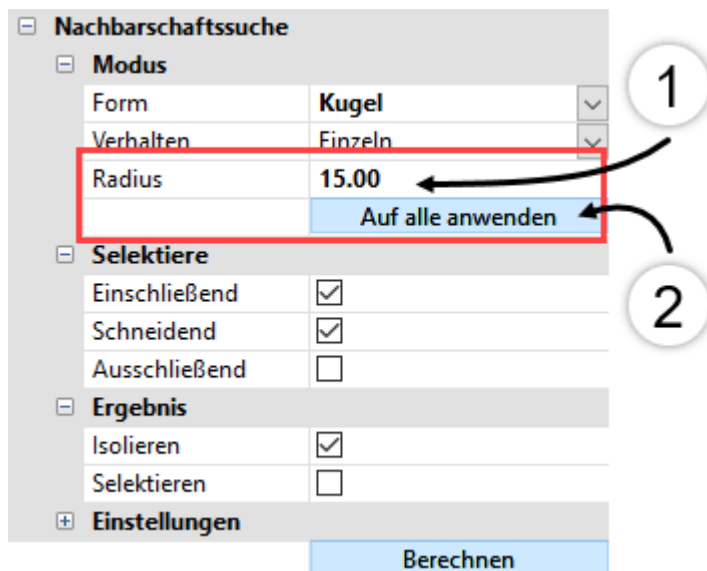

- Start the search by activating the **[COMPUTE]** button.

2.10 Customizing the View

The **VIEW** tab offers further visualization options.

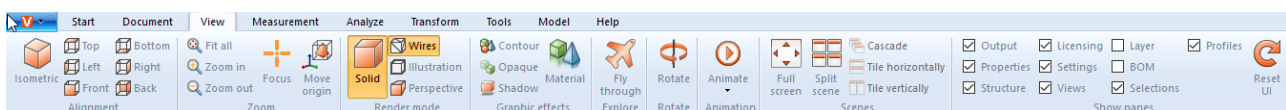

The isometric view is preconfigured with a 45° vertical and horizontal angle. The configuration of these angles can be changed via **SETTINGS > DEFAULT > SCENE > CHANGE ORIENTATION** (see ch. [Settings](#)^[18]) or those of the current scene by clicking the background under **PROPERTIES > SCENE PROPERTIES > ALIGNMENT** (see chapter [View and Edit Properties of Selected Objects](#)^[25]).

In the **Zoom** area, the **Focus** function allows you to center a selection (see chapter [Object Selection](#)^[23] and [Saving Selections](#)^[24]) in the Model Area. This function is useful to focus on a node selected in the structure (e.g. sub assembly). This function is also available in the context menu (right click).

The functions **RENDER MODE** and **GRAPHIC EFFECTS** adjust the scene of the current model. You can, for example, display the wireframe without fill, switch to monochrome rendering of the model in the Illustration mode or click the **OPAQUE** button to temporarily remove the transparency of all geometries. In other words: these are simply display effects, which have no effect on an export.

You can also use the option **SHADOW** to add a shadow thrown by the part. You can influence the behaviour of the shadow in **PROPERTIES > SCENE PROPERTIES > VISUALIZATION > SHADOW**.

The **SPLIT SCENE** function offers four independent views of a model.

You can view several models simultaneously in the tab view (default) by simply dragging a tab into the model area. Drag the same tab back to a position next to another tab to return to the original view.

Using the pane view instead of the tab view will allow an arrangement of the model panes via the function **CASCADE**, **TILE VERTICALLY** and **TILE HORIZONTALLY**. The pane view is enabled when the tab view is disabled in **SETTINGS > APPLICATION > UI**.

Under **SHOW PANES** you can hide or show panes such as the **LICENSING** pane. You can also reset the entire user interface to its default settings; this action will not affect settings or profiles.

2.11 Views

Specific work steps can be captured by generating a view of the current scene via the sub pane **VIEWS** in the **STRUCTURE** area.



Function	Description
START	Enables the view displayed at last save.
CREATE	Generates a view from the current scene.
UPDATE	Overwrites the selected view with the current scene.
DELETE	Deletes the selected view(s).
PLAY	Starting with the selected view, the previous (Reverse play) or the subsequent (Play) views will be displayed.
STOP	Stops the playing of views.
REVERSE SEQUENCE	Reverses the sequence of the selected views.
UPDATE BACKGROUND COLOR FOR THE SELECTED VIEWS	Updates the background color only for the selected views.
SAVE CURRENT VIEW IN PDF	Saves all views as PDF
SAVE CURRENT VIEW IN PNG	Saves all views as PNG
SAVE AN OVERVIEW OF ALL VIEWS AS PDF	Saves all views on a page as a PDF

- Double clicking a view restores this scene.
- A view can be repositioned via click & drag.
- Left-click on the name of the selected view to rename it.
- Click on the **SAVE AS** (see chapter [Save](#)⁹⁷) to store the model with all views in the KISTERS 3DVS format.

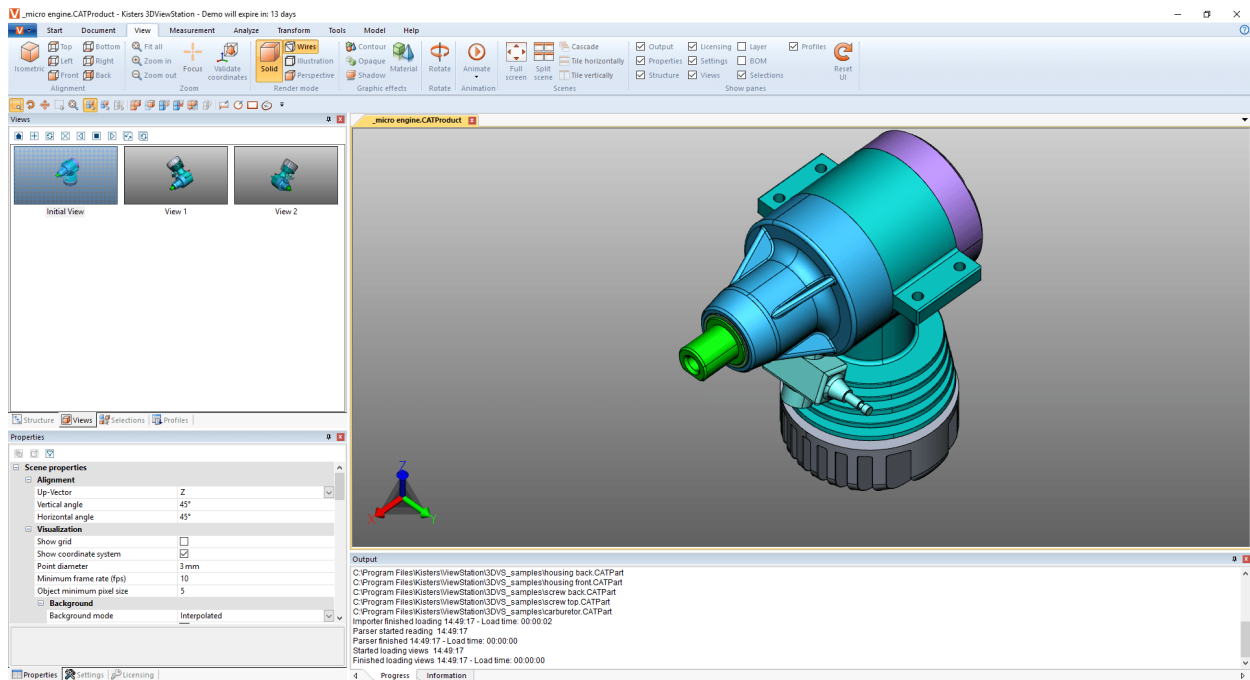

2.12 Measurement

In this chapter, you will find detailed descriptions of these measurement functions:

- [General Settings](#) ³⁴
- [Point Coordinate](#) ³⁵
- [Length](#) ³⁶
- [Circle](#) ³⁶
- [Distance](#) ³⁷
- [Angle](#) ³⁸
- [Face](#) ³⁹
- [Wall Thickness](#) ³⁹
- [Bounding Box](#) ³⁹
- [Drill Hole](#) ³⁹

2.12.1 General Settings

General Settings lists all settings that are used for all measurements (if applicable).

Snap Modes

This is important for all functions that snap to points (e.g. **MEASUREMENT**, **TRANSFORM**, **SECTION**).

You can decide what kind of points to snap to when hovering over a model:



Icon	Function	Description
	Free	If enabled, all possible points will be highlighted when moving the mouse pointer over them.
	End	If enabled, the end points of wires/edges are highlighted when moving the mouse pointer over them.
	Center	If enabled, the center points of wires/edges are highlighted when moving the mouse pointer over them.

These options can be combined. For example, the default is **END** and **CENTER**, which snaps the highlighting to the end or center point closest to the mouse position, ignoring all other points. If you also enable **FREE**, all possible points on the geometry are selected, and the highlighting only snaps to an end or center point when you get close to one of them.

These settings can be changed in either ribbon view **MEASUREMENT** or **TRANSFORM**. They are also found in the **SCENE SETTINGS**.

Circle Mode

This is important for all functions that pick circles (e.g. **MEASUREMENT**, **TRANSFORM**, **SECTION**). It can be changed in either ribbon view **MEASUREMENT** or **TRANSFORM**.

Icon	Function	Description
	Arc	The default is to select a circle by finding arcs in the geometry. If this option fails, a circle can be selected using the 3-points feature.
	3 points	If enabled, you can select three points on the geometry to define a circle for the measurement, transformation or section feature. To determine the three points on the geometry, you first need to set the correct Snap Mode [34] for your selection.

Tip

- There are advanced settings for calibrating the Arc feature.
- Click on **SETTINGS** in the **Info Area** [\[8\]](#) and switch to the **DEFAULT** tab. In the tree view, navigate to **SCENE > TOOLS > CIRCLE DETECTION**.





Dimensioning

Coming soon.







2.12.2 Point Coordinate

Icon	Function	Description
	Point	This function provides you with the coordinates (X, Y, Z) of the point you have selected. The coordinates are relative to the active coordinate system [84] .

2.12.3 Length







Icon	Function	Description
	Edge	Use this function to measure the length of an edge or line.
	Cumulative edge	Use this function to measure the length of multiple edges or lines. Select the edges one by one. When you have selected all edges, click on COMPLETE or click the right mouse button to finalize the measurement. You can also create a selection of lines beforehand, then start the measurement and click on FROM SELECTION .
	Point to point (wire)	Use this function to measure the length between two (or more) selected points on edges/wires along these edges/wires. If the points can't be connected by edges/wires, there will be no result. Also see Snap modes  .

2.12.4 Circle

Icon	Function	Description
	Radius	Use this function to measure the radius of the highlighted circle.
	Diameter	Use this function to measure the diameter of the highlighted circle.
	Perimeter	Use this function to measure the perimeter of the highlighted circle.
	Center	Use this function to measure the circle center coordinates of the highlighted circle. The coordinates are relative to the active coordinate system  .
	Area	Use this function to measure the area of the highlighted circle. Also see Circle mode  .

2.12.5 Distance

To measure distances the following six different snap functions are used:

Icon	Function
	Point
	Edge
	Face
	Solid
	Circle center
	Circle axis





You can select a specific measurement method from the drop-down list or select **USER DEFINED**. In either case, a small overlay appears in the right upper corner of the scene. Here you can see which measurement method is active, and you can switch between methods, even in the middle of a measurement (Function available as of version 2024.4).











The 3DViewStation measures the shortest distance and the distance in the X, Y and Z directions of the [active coordinate system](#)^[34].

Also see [Snap modes](#)^[34] and [Circle mode](#)^[34].

Specialized distance measurements



Icon	Function	Description
	Circle center (pipe) to face	This function is located at the bottom of the DISTANCE drop-down list. Measures the distance between the center of a pipe and a surface. You first select a point on the outside of a pipe to get the center of the pipe, then you select a face. Also see Snap modes  .
	Solids to Solids	This function can be used to find the shortest distance between multiple solids. There are two options (COMPUTATION TYPE) for this calculation that you can select in the Tool Area  SELECTED VS UNSELECTED: You select one or more solids, and they are measured against the unselected solids. SELECTED AGAINST EACH OTHER: All selected solids are measured against each other to find the shortest distance.

2.12.6 Angle



Icon	Function	Description
	Circle axis to circle axis	Use this function to measure the angle between two circle axes.
	Circle axis to edge	Use this function to measure the angle between a circle axis and an edge.
	Line to line	Use this function to measure the angle between two intersecting lines.
	Line to line (projected)	Use this function to measure the angle between any two lines. You have to define the direction (X (default), Y, Z) of the active coordinate system  to define the projection direction. This will project the second line onto the first in that direction, and if they intersect, it will return a result.
	Plane to plane	Use this function to measure the angle between two planar faces.
	Plane to axis	Use this function to measure the angle between a planar face and one of the active coordinate system  axes (X (default), Y, Z)
	Three points	Use this function to measure the angle between any of the three given points. The second point is the shared endpoint.

Also see [Snap modes](#) .

2.12.7 Face



Icon	Function	Description
	Area	Use this function to measure the area of the one face.
	Cumulated area	Use this function to measure the area of multiple faces. Select the faces one by one. When all faces are selected, click COMPLETE in the Tool Area or right-click to complete the measurement.

2.12.8 Wall Thickness

Icon	Function	Description
	Ray	Use this function to measure the wall thickness at any given point by projecting a ray through the geometry.
	Sphere	Use this function to measure the wall thickness at the given position by enlarging a sphere until it touches the geometry somewhere else. The result is the diameter of the sphere.

2.12.9 Bounding Box

A bounding box is a cuboid that surrounds the selected geometry and can be calculated in three ways:

Icon	Function	Description
	World	The calculated bounding box is aligned with the world coordinate system (X, Y, Z).
	Part	The calculated bounding box is aligned to the part coordinate system. If you select more than one geometry, a separate bounding box is calculated for each part.
	Minimal	This calculates the minimum bounding box and ignores any orientation.

2.12.10 Drill Hole

Icon	Function	Description
	Drill hole	Select the top circle of the hole you want to measure. You will see values for diameter, depth, and chamfer.

2.13 Section

You can furthermore place multiple types of sections across models:

Function	Description
NORMAL	Generates a cutting plane at a selected point above the normal of the surface.
AXES	Generates a cutting plane at the center of the model's Bounding Box.
3 POINTS	Generates a cutting plane across any three specified points.
3 CIRCLE CENTERS	Generates a cutting plane across the centers of three selected circles.
LINE	Creates a section plane perpendicular to the center of the selected line.

1. Activate the section function by clicking the corresponding function button in the **ANALYZE** tab.

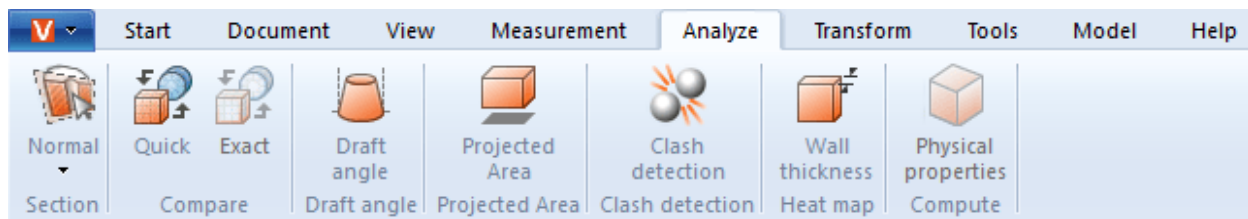

2. The tool pane **SECTION** appears, where the cutting plane properties can be modified.
3. Move the cutting plane by clicking the auxiliary objects and move the cursor or enter relevant values in the **MOVEMENT** area.
MOVE and **ROTATE** return the offset to the original position. In other words: entering the value "0" will return the cutting plane to its original position. The original position will be redefined by clicking the handles or by entering position coordinates.
4. Clicking the button **CENTER HANDLE** will reposition the handles centrally in the visible area if they are no longer visible (e.g. due to zooming in closely).
5. Various visualization options are provided at the top of the tool pane.
6. The currently active temporary cut can be exported as a vector graph as needed (DXF and SVG). Using the **SCREENSHOT** function (see chapter [2D Export \(Screenshot\)](#)) in the **TOOLS** tab, the entire model area including the section can be saved.
7. The cut can also be created as a geometry in the structure of the model, making it available for further analysis and export. The cut geometry can be generated as a wire or an area.
 With a **STEP WIDTH** of "0.0" or if **CREATE MULTIPLE** is disabled, only the current section is created as geometry. Multiple steps can be generated if a step width value is entered in the model unit. These can be found in the model structure in the newly created node **CREATEDNODES**.

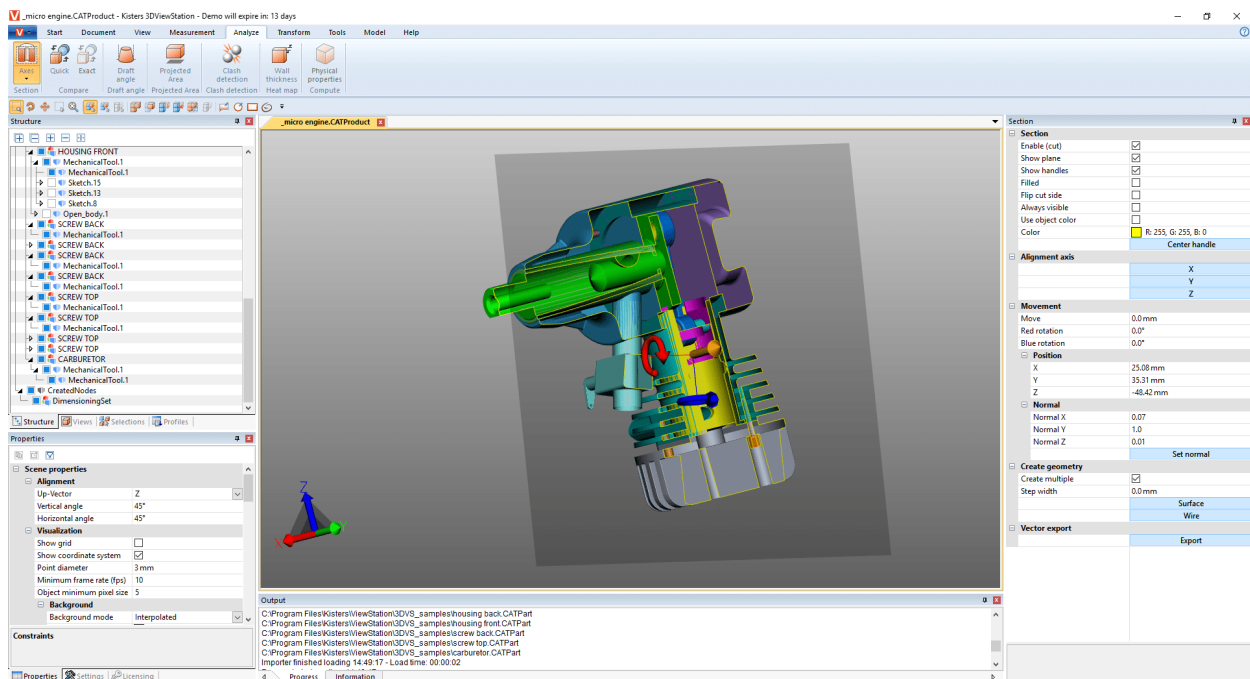

8. Exit the section function by clicking the button again or by pressing [ESC].

2.14 Comparison of parts, assemblies and drawings (3D and 2D)

The comparison function allows you to find differences between individual parts, entire assemblies, or drawings. Here you can choose between quick compare (3D and 2D) and exact compare (only 3D).

Quick compare is based on the displayed 3D model scene or the 2D drawing without any prior calculation and offers a quick overview using coloring of the visible surfaces.

An exact compare, on the other hand, is possible only on the basis of 3D geometry data (BREP) and requires a calculation of the result. It is anchored in the model structure as a new geometry under the node **COMPARERESULTS** and will therefore be available for further analysis and export. The unchanged geometries and those that are identical in both models, as well as the geometries of the first model (Name-of-the-first-Model) that differ from those of the second model, and the geometries of the second model (Name-of-the-second-Model) that differ from those of the first model.

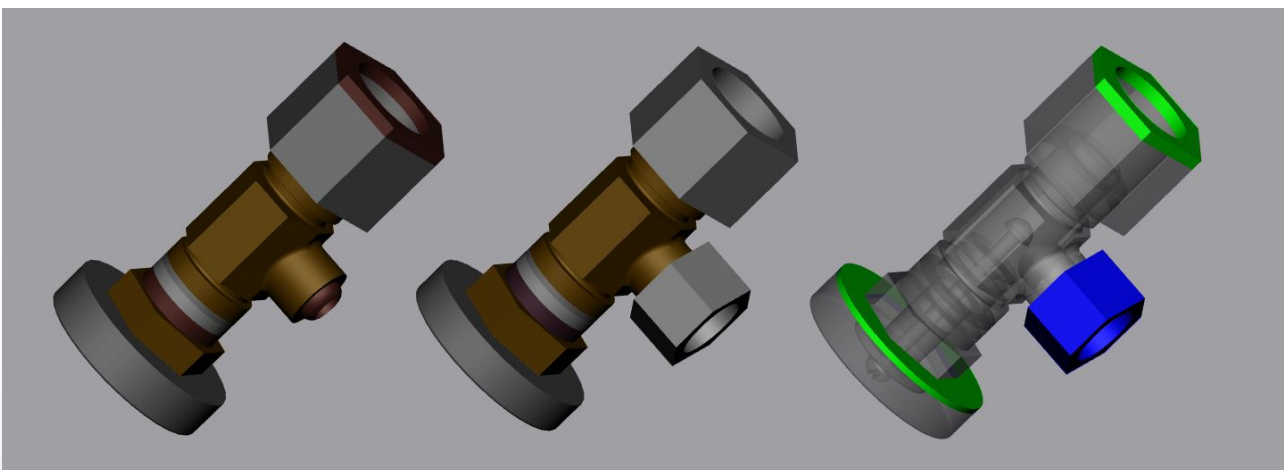

Proceed as follows to compare two models:

- Load the first model into the 3DViewStation by opening or drag and drop.
- Import the second model for comparison into the open model via Import or drag and drop into the model area. Both parts, assemblies or drawings must lie congruently on top of the other, if this is not the case you can position the models using the transformation operations described in chapter [Transformations \(Move, Rotate, Mirror and Explode\)](#) .

- Select the two models for comparison e.g. from the model structure. Without a selection, the two top nodes of type **ROOT** will be compared.
- Start the compare function by clicking the **QUICK COMPARE** or **EXACT COMPARE** button in the **ANALYZE** tab. The visualization of the comparison can be configured in the tool pane; the exact comparison must be initiated here via the **COMPUTE** function.
- The result of the comparison can be exported to various image formats (see chapter [2D Export \(Screenshot\)](#)^[97]) via the screenshot functions in the **TOOLS** tab and saved as views (see chapter [Customizing the View](#)^[32]). Since the exact comparison generates new geometries, these can be used for further analysis and can also be exported.
- Exit the compare function by clicking the active button within the function area again or by pressing [**ESC**].

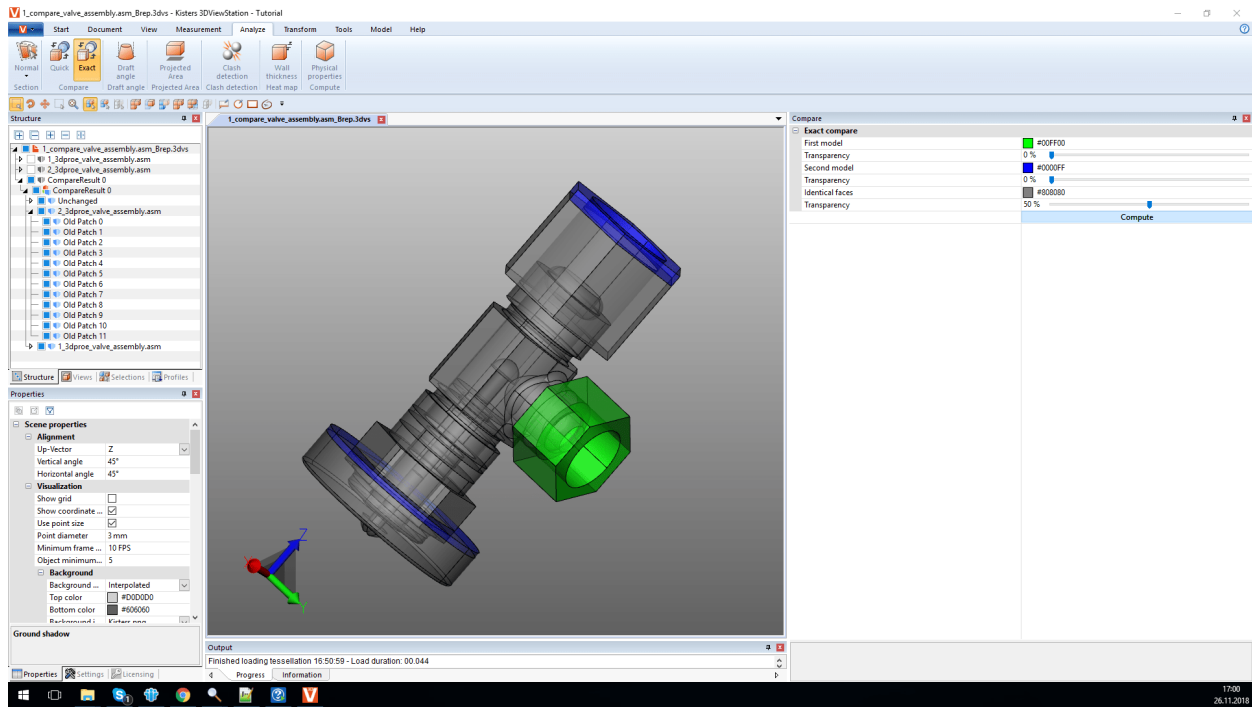

2.15 Structure Compare

This functionality is available **from version 2024.6**.

Toolpane Settings

This chapter describes the tool settings of the Structure Compare function.



Setting / Button	Default value <small>(If multiple options are available, the default is bold.)</small>	Description
Structure compare		
Node filter	<ul style="list-style-type: none"> ▪ All ▪ Structure tree ▪ Product occurrence 	Choose which nodes will be used during the comparison (Default: "All"). Alternative: - "Product occurrence": only uses the lowest product occurrences for the comparison.
Visible	true	On: Hidden nodes will be ignored.

Setting / Button	Default value (If multiple options are available, the default is bold.)	Description
only		
List identical nodes	false	On: Also list nodes that have no changes.
Maximum number of changes	3	Nodes with more changes will be considered to be entirely different nodes. If this number is set too high, it may cause false positives.
Show attributes	true	On: Adds an additional output column for each attribute in "Attributes to display".
Attributes to display		Lists all attributes/properties to be contained in the table output. Click on the three points at the end of the field to open a dialog, where you can choose the attributes/properties.
Remove empty columns	true	On: Columns where all values are empty will be removed from the table.
Filters		
Structure	true	Node was added, removed or moved within the structure.
Geometry	true	Whether the node geometry has changed.
Physical properties	true	Changes to physical properties (volume, area, density or mass).
Attributes	true	Attributes added, removed or value changed.
Transformation	true	Rotation, translation, scale.
Appearance	true	Changes to color, material or texture.
Visibility	true	Node visibility was changed.
Text	Note	Changes of texts, e.g. CustomIds or PMI texts.
File path	true	File path of the node (if available).
Visualization		



Setting / Button	Default value (If multiple options are available, the default is bold.)	Description
Show comparison by	<ul style="list-style-type: none"> ▪ Selection ▪ Ghost other parts ▪ Hide other parts 	Type of visualization when selecting an entry.
Zoom fit	true	Fits the selected geometry into the visible area.

Tutorial

This function allows you to compare the structure of two parts or two assemblies within one scene.

- Open the first file.
- On the **START** ribbon, in the **FILE** section, click **IMPORT** to add the file you want to compare to the first file.
- On the **ANALYZE** ribbon, in the **COMPARE** section, click **STRUCTURE** .
- You can configure the output you want to receive with the settings in the **Tool Area** .
- Finally, click on **COMPUTE**.

The result is displayed in the table at the top of the window. When you click an entry in the table, the compared geometries are selected and fitted into the view (default; see **Toolpane Settings > Visualization**  for more options).

Icon	Function	Description
	Export	If you want to save the results or need them for further processing, you can export the table to different formats: Text, CSV, XML, JSON or an HTML table.
	Copy to Windows clipboard	Instead of exporting to a file, you can also copy the table to the clipboard. The formats mentioned above are also available here and can be set per preference.

2.16 Projected Area

In the **ANALYZE** functional area, you can use the **PROJECTED AREA** tool to visualize the projected area for parts and assemblies and compute their surface area.

Proceed as follows to calculate the projected area of a selection:

- Create a selection (see chapter [Selecting objects](#) ²³).
- In the **ANALYSIS** tab, activate the **PROJECTED AREA** function.
- In the **tools area** ⁸, specify the projection axis relative to the current coordinate system (see chapter [Generate Coordinate System](#) ⁸⁴).
- Click the **[COMPUTE]** button in the Tool Area.
- The projected area is now displayed in orange.
- The calculated area will be displayed in the tool area under **AREA**.

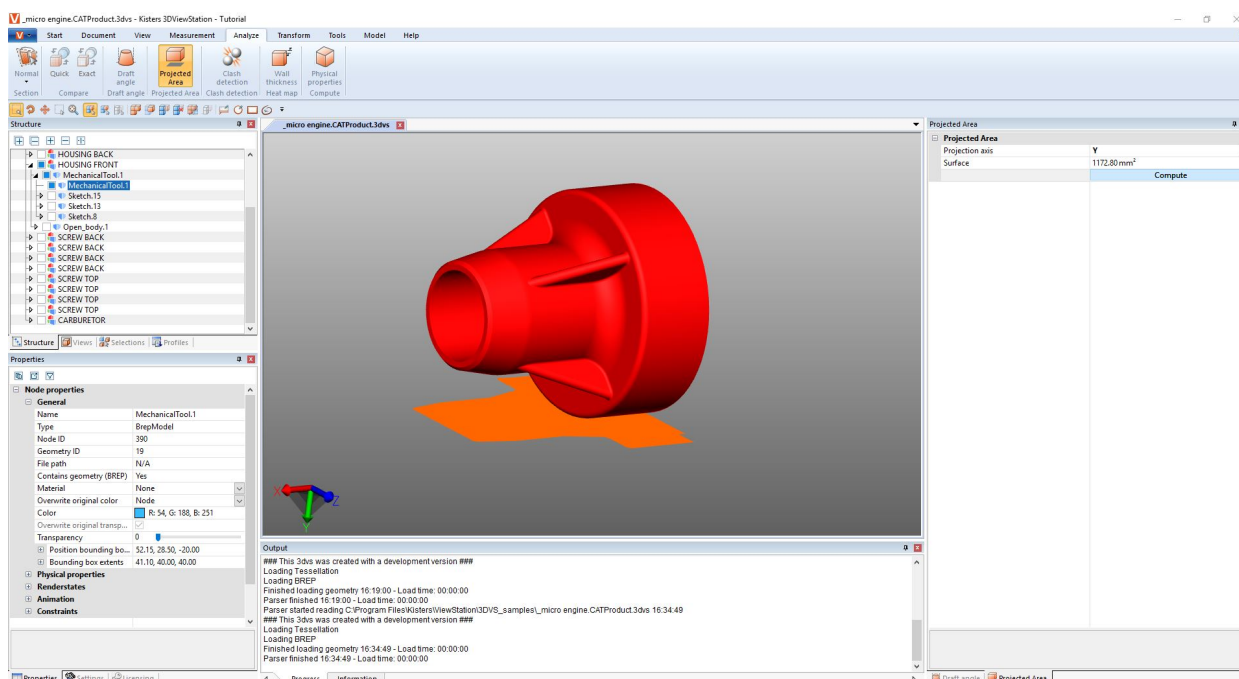

2.17 Neutral Axis, calculate straight length

The function **NEUTRAL AXIS** can be accessed via the **ANALYZE > FEATURE RECOGNITION** tab.

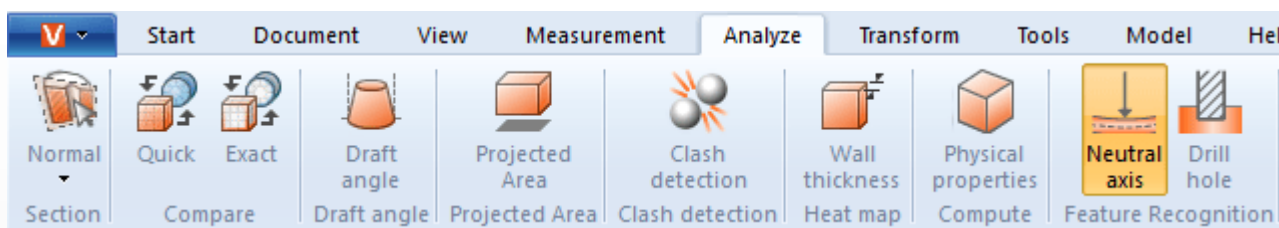

A neutral axis (zero line) is the axis or layer of a beam or tube cross-section whose length does not change with twisting or bending. With this tool the stretched length for circular tubes can be determined, independent of their bending. This is why this function is sometimes called the "extended length calculator". The neutral axis is calculated on the basis of individual segments. A segment is formed by two circles connected by a straight line or forming an arc.

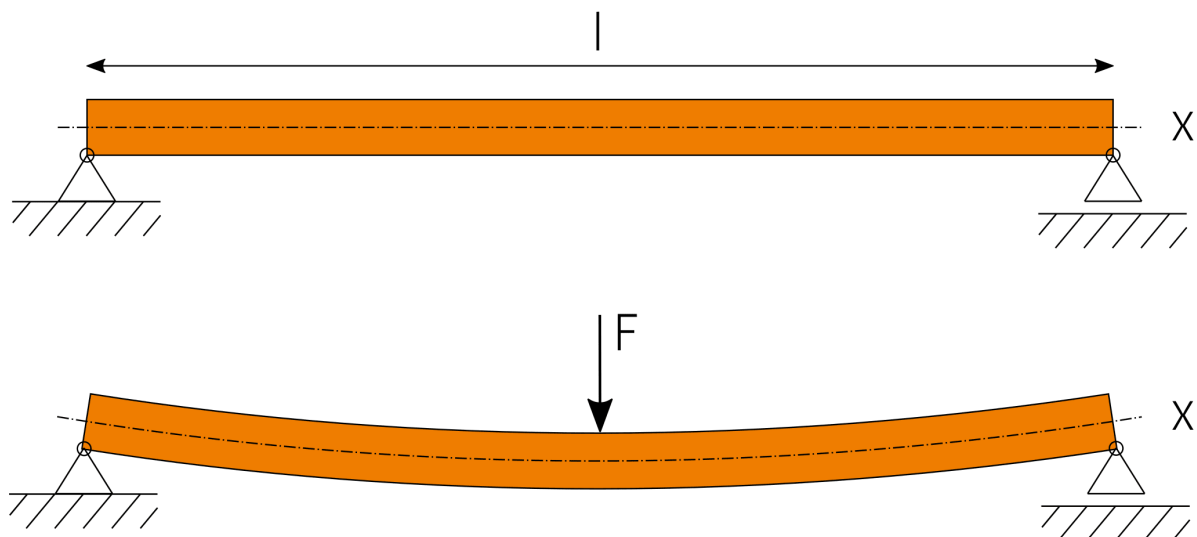
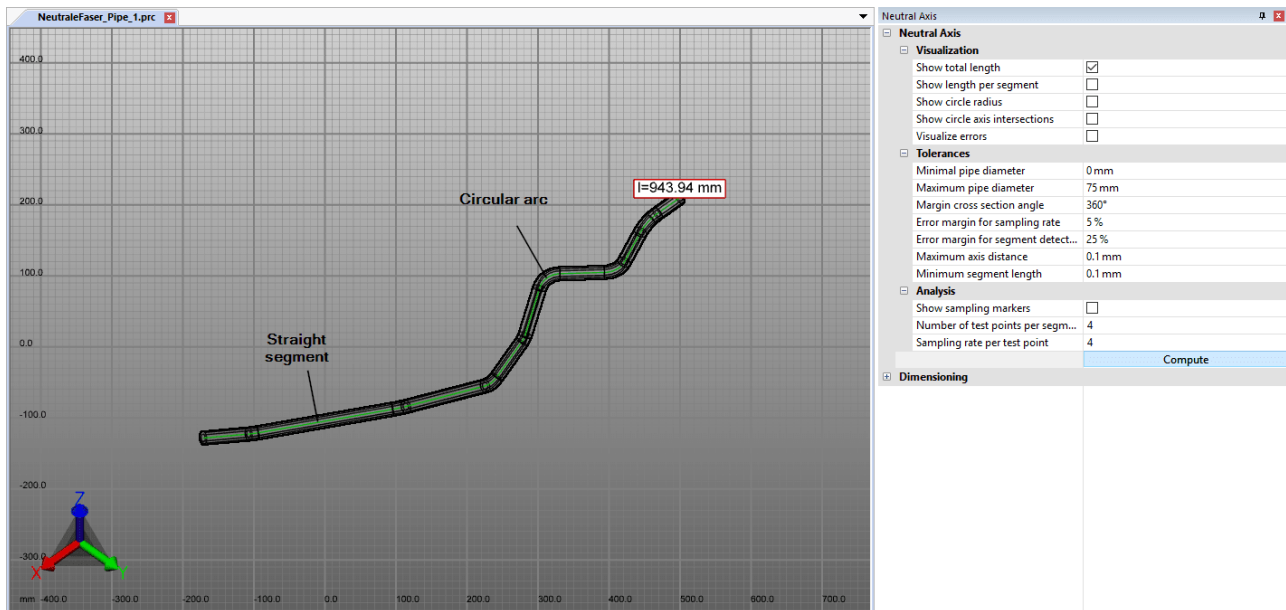

To calculate the neutral axis, proceed as follows:

- Activate the **NEUTRAL AXIS** function via the **ANALYZE** tab.
- Create a selection for the calculation. Without a selection, the neutral axis is calculated for all visible geometries with a circular cross-section.
- If necessary, adjust the settings and then start the analysis using the **[COMPUTE]** button.
- Geometries for visualization and dimensioning are created as **NEUTRALAXISSET** under the **CREATEDNODES** node.

To obtain information on the individual settings, click on a setting in the tool area. You will then receive detailed descriptions of the respective setting in the lower area of the windows - in the so-called **Help Box** .

2.18 Draft

In the tab **ANALYZE**, you will find the tool **DRAFT** for the evaluation of possible demolding directions of a part or assembly. Depending on the specified direction, the entire visible model will be colored according to specification.

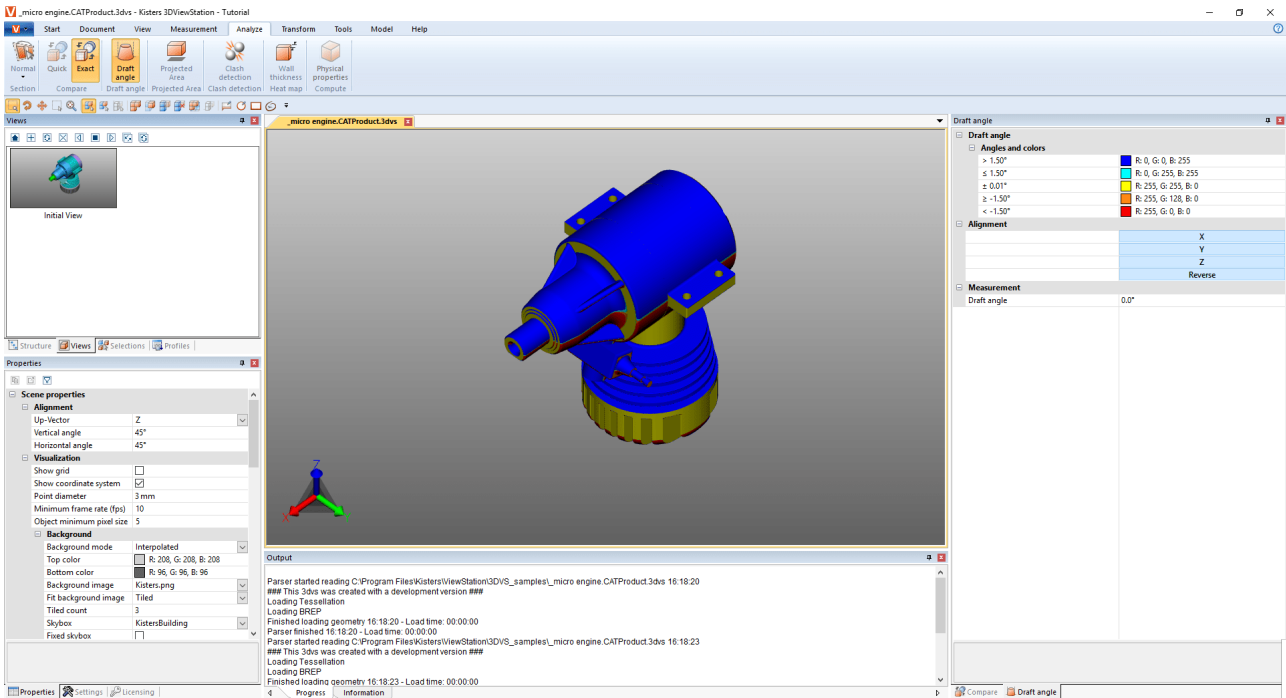

Proceed as follows to initiate a draft analysis:



- Start the draft analysis; the cursor is displayed as an orange arrow.
- Move the cursor over the model. The cursor will always be perpendicular to the area below. It will also follow line objects and coordinate system axes to verify specified directions in the model as needed.
- Click the left mouse button at the desired positions to color the model in accordance with that draft direction.
- The draft angles and their associated colors can be specified in the tool pane. Areas positioned at the specified angle to the draft direction will be colored accordingly.
- The tool pane additionally offers the option to reverse the draft direction or to align it with the current coordinate system (chapter [Generate Coordinate System](#) 84).
- The orange cursor for aligning the demolding direction can also be aligned with lines and coordinate systems.
- Move the cursor over the model again to display the angle of the area perpendicular under the cursor in relation to the current draft direction in the tool pane under **DRAFT**.





2.19 Wall Thickness



► Toolpane Settings

This section describes the tool settings of the Wall Thickness function.

Setting Button	Default value <small>(If multiple options are available, the default is bold.)</small>	Description
Wall thickness analysis		
Presets		Presets for fast or visual qualitative computation. Default is "User defined" (see the "User defined" section for specific settings).

Setting Button	Default value (If multiple options are available, the default is bold.)	Description
		 Presets can be adjusted and added: Installation directory\Resources\presets.xml
User defined		
Mode	<ul style="list-style-type: none"> ▪ Ray-based ▪ Rolling ball 	Ray-based: Calculates the wall thickness by firing a ray through the geometry. Rolling ball: Calculates the wall thickness by the largest possible spheres that fit into a geometry.
Use relative accuracy	true	On: The "Relative accuracy" is used. Off: The "Absolute accuracy" is used.
Relative accuracy	0.01 %	A percentage value to define the accuracy of the calculation. Smaller values improve the result but increase processing time.
Absolute accuracy	1.0	An absolute value to define the accuracy of the calculation. Smaller values improve the result but increase processing time.
Rolling ball		
Angle tolerance	25.0	Optimizes the results of the rolling ball calculation by ignoring angles below the tolerance value that would create very small spheres.
Validate result	true	Validates the result by using a raycast, e.g. to locate geometry that is not closed or is otherwise invalid.
Compute		Starts a wall thickness calculation. Settings below can be changed before and after the calculation.  A new calculation will overwrite the color map values, if "Freeze min/max values" is off.
Visualization		
Limit values to min/max		Off: Values above the maximum or below the minimum values of the defined "Color map" will be shown in the color defined by "Outside min/max color". On: The color of the minimum or maximum value will be assigned to the values outside the color map range.
Outside min/max color		This color will be assigned to values outside the "Color map" range, if setting "Limit values to min/max" is off.
Outside		Off: Show values outside of the color map value range in the color defined

Setting / Button	Default value (If multiple options are available, the default is bold.)	Description
min/max transparent		with "Outside min/max color". On: Values are hidden, if they are outside of the color map min/max values.
Freeze min/max values		Off: New calculations will overwrite the "Color map" values. On: Color map values will be kept for new calculations.
Color map presets		Presets that contain predefined colors and the "Number of values" for the "Color map". Shows "User defined" when no preset matches the "Color map" settings chosen.  Presets can be adjusted and added: Installation directory\Resources\presets.xml.
Reverse colors		On: Reverses the color sequence of the "Color map".
Show color bands		Off: Shows a gradient transition between colors on the geometry and in the legend. On: Shows color bands instead.
Color map		
Number of values		Number of values and colors.  Changing the number will trigger a recalculation of the intermediary values and colors.
Reset min/max		Resets all "Color map" values to the min/max values of the calculation.  Ignores "Freeze min/max values".
Value automation		
Update intermediate values		Interpolates the intermediate values of the color map.  Helpful after editing the min/max values of the color map.
Apply quantiles		Removes outlying values from the color map. The top and bottom 5 % of values are ignored to focus on the values in the middle.
Apply logarithmic scale		Uses a logarithmic scale on the color map.

Setting / Button	Default value (If multiple options are available, the default is bold.)	Description
		 Sometimes linear intervals obscure very small but important value ranges that are close together. This spreads those small ranges and assigns them a larger color spectrum, making them more expressive.
Miscellaneous		
Apply selection to others		Color map results with different settings cannot be meaningfully displayed in the legend. This applies the settings of the selected result to all other visible results and updates the color map and legend accordingly.
Unify properties		If two or more heatmap nodes (of the same type) with different visualization properties are selected, they have to be unified before we can display the visualization settings.
Legend		
Show histogram	false	On: Color legend shows a dotted line indicating the frequency distribution of the values.
Number of decimal places	4	Specifies the displayed decimal places of the color map values.
Show equidistant values	false	Off: All legend intervals are spaced according to their numeric value. On: All legend intervals are spaced with equal distances, irrespective of their numeric values.  This improves visibility for very small intervals.

► Tutorial

Ray-based

Use Ray-based mode to detect thin areas and sharp edges.

- Open the 3D model from the following folder: <Installation folder 3DViewStation>/Samples/micro_engine.CATProduct.3dvs
- Isolate the **HOUSING FRONT** geometry in the structure area.
- Activate the **ANALYZE** tab in the function area.
- Select the **WALL THICKNESS**  function from the **MOLD** function group.
- Select **RAY-BASED - VERY DETAILED** from the presets.

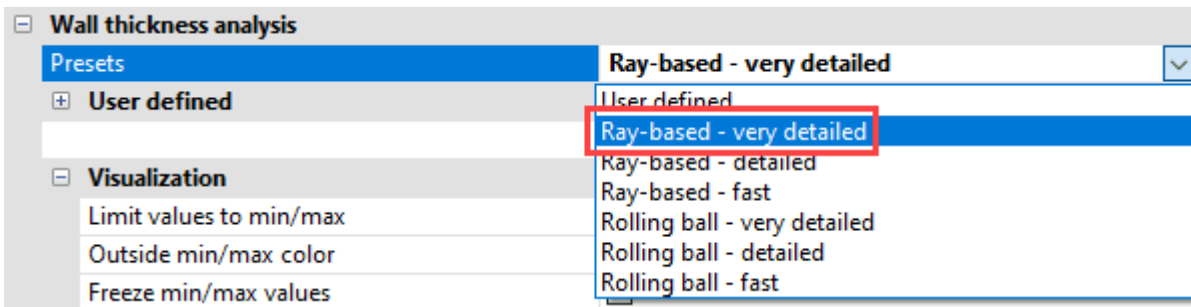

- Click on **[COMPUTE]**.
- Set the last value in the color map to 5 mm. As a result, you have a more relevant scale for the use case at hand.
- Click on **[UPDATE INTERMEDIATE VALUES]**.
- View the geometry from below (**VIEW > BOTTOM**) to see the sharp edge (red) of the hole.

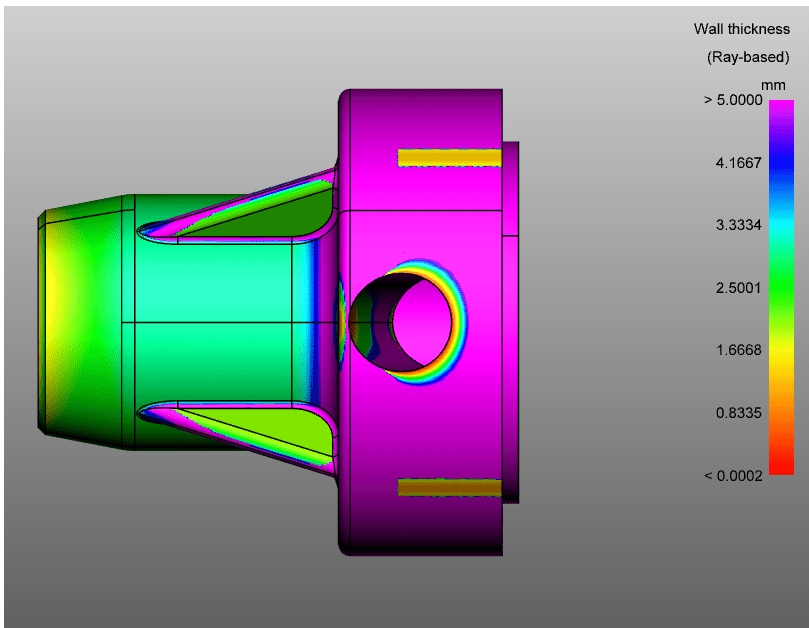

Rolling ball

Use the Rolling ball mode to detect areas with large material thickness.

- Open the 3D model from the following folder: <Installation folder 3DViewStation>/Samples/micro_engine.CATProduct.3dvs
- Isolate the **HOUSING** geometry in the structure area.
- Activate the **ANALYZE** tab in the function area.
- Select the **WALL THICKNESS**  function from the **MOLD** function group.
- Select **ROLLING BALL - VERY DETAILED** from the presets.
- Click on **[COMPUTE]**.
Areas with the highest concentration of material are shown in blue and purple.

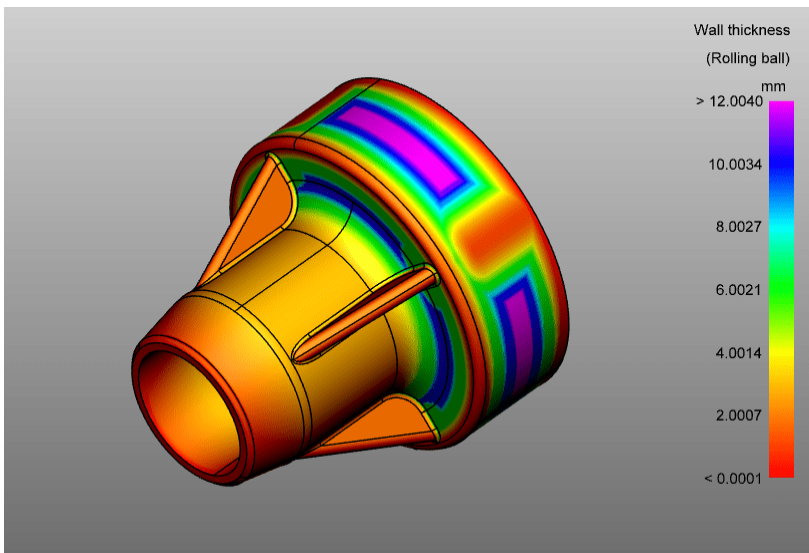

Tip

- If you have already set the color table values you are interested in, activate **FREEZE MIN/MAX VALUES** to prevent overwriting during calculation.
- Turn on **SHOW HISTOGRAM** to see the distribution of values.
- The difference between selected and unselected color map node: brighter colors.
- Changes to the visualization and legend settings are only applied to already created color map nodes if they are selected.

► Blog post

The following video demonstrates the Curvature Analysis feature and the advanced color maps (heatmaps) for viewing certain results of the advanced 3D functions such as Wall Thickness and Band Analysis.



[Link to the blog post](#)

2.20 Clash Detection

The Clash Detection calculates a list of the clashing parts in an assembly. You can also compute additional parameters like **PENETRATION DEPTH** and select various types of visualizations.

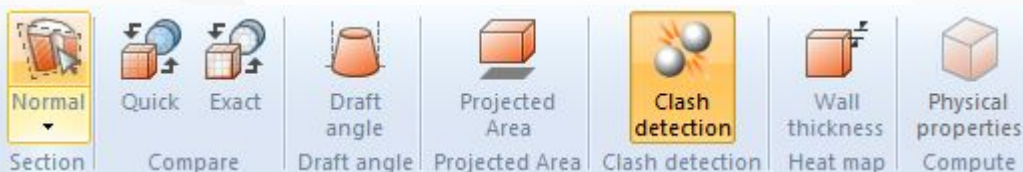

- Activate the **CLASH DETECTION** function by clicking the button with the same name in the **ANALYZE** tab.
- In the **tool area**, the collision pair list is displayed in the upper area. You can select the following parameters for clash detection in the Tools pane:
 - a. In the tree structure, under **COLLISION DETECTION > COMPUTE**, you can have various measurements calculated as well, such as the cutting edge, the penetration depth and the collision volume.

- b. **CONTACT/COLLISION THRESHOLD** specifies the penetration depth in the model unit, from which collision pairs are no longer classified as **CONTACT**. This tolerance value can be used to e.g. balance out any inaccuracies in the tessellation.
- c. You can select the parts for which a possible clash is to be examined from the **COMPUTE CLASH FOR** selection list:
- **VISIBLE PARTS:** All parts will be included that are not ghosted or hidden.
 - **SAVED SELECTION SETS:** Computes collisions only for previously [saved selection sets](#) ^[24].
- Initiate the clash detection via the **COMPUTE** button. The computing time will depend on the model size and processing power of your computer. You can continue interacting with 3DViewStation while the process is running. The progress of a current computation of detail information can be viewed via the button **[COMPUTING]**.
 - By selecting a row in the clash list, you can highlight the corresponding pair and specify the type of display in the section **VISUALIZATION**:
 - Show clash by:
 - Selection: The pair is selected.
 - Hide other parts: All parts except the selected pair are hidden.
 - Ghost other parts: All parts except the selected pair are displayed as in ghost mode.
- a. Zoom fit: The selected collision pair is zoomed to fit the image.
- b. Clash pair transparency: Transparency control for the analysis of clashes in covered areas.

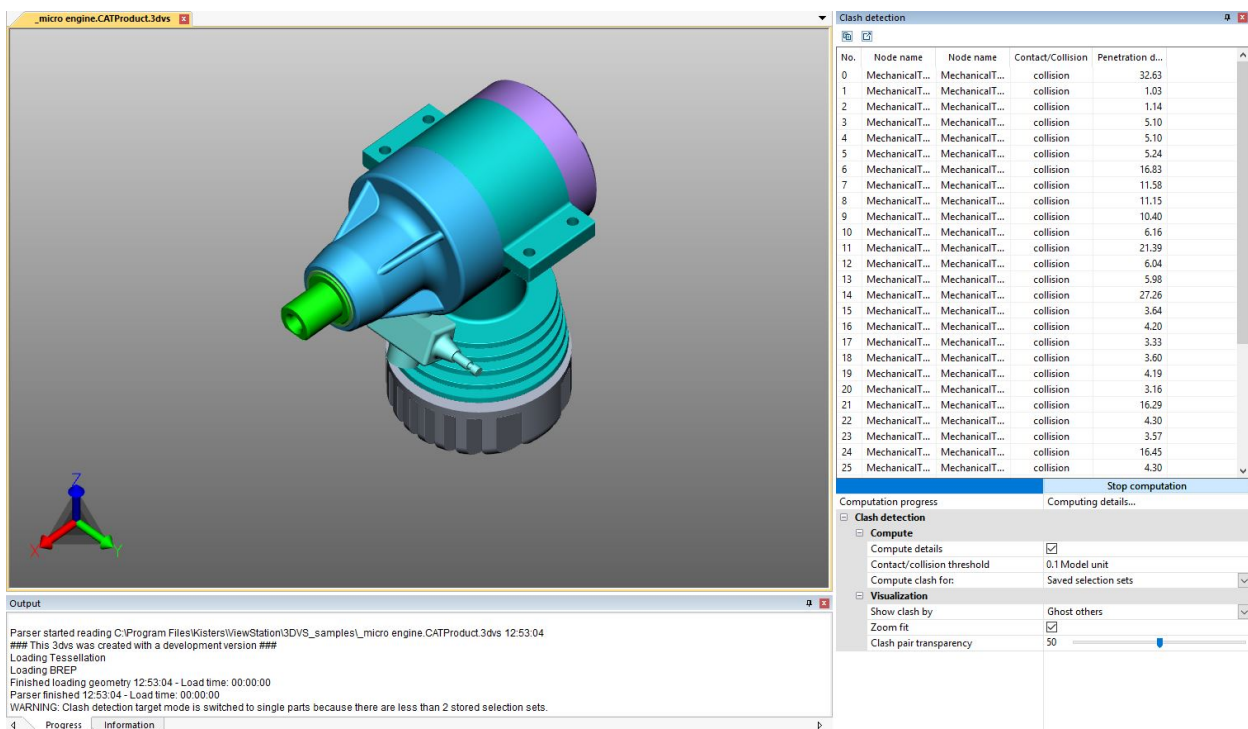

The screenshot displays the 3DViewStation software interface. On the left, a 3D model of a mechanical assembly is shown with a clash detection overlay. On the right, the 'Clash detection' panel is visible, containing a table of collision data and configuration options.

No.	Node name	Node name	Contact/Collision	Penetration d...
0	MechanicalT...	MechanicalT...	collision	32.63
1	MechanicalT...	MechanicalT...	collision	1.03
2	MechanicalT...	MechanicalT...	collision	1.14
3	MechanicalT...	MechanicalT...	collision	5.10
4	MechanicalT...	MechanicalT...	collision	5.10
5	MechanicalT...	MechanicalT...	collision	5.24
6	MechanicalT...	MechanicalT...	collision	16.83
7	MechanicalT...	MechanicalT...	collision	11.58
8	MechanicalT...	MechanicalT...	collision	11.15
9	MechanicalT...	MechanicalT...	collision	10.40
10	MechanicalT...	MechanicalT...	collision	6.16
11	MechanicalT...	MechanicalT...	collision	21.39
12	MechanicalT...	MechanicalT...	collision	6.04
13	MechanicalT...	MechanicalT...	collision	5.98
14	MechanicalT...	MechanicalT...	collision	27.26
15	MechanicalT...	MechanicalT...	collision	3.64
16	MechanicalT...	MechanicalT...	collision	4.20
17	MechanicalT...	MechanicalT...	collision	3.33
18	MechanicalT...	MechanicalT...	collision	3.60
19	MechanicalT...	MechanicalT...	collision	4.19
20	MechanicalT...	MechanicalT...	collision	3.16
21	MechanicalT...	MechanicalT...	collision	16.29
22	MechanicalT...	MechanicalT...	collision	4.30
23	MechanicalT...	MechanicalT...	collision	3.57
24	MechanicalT...	MechanicalT...	collision	16.45
25	MechanicalT...	MechanicalT...	collision	4.30

The 'Clash detection' panel also includes configuration options for computation and visualization. The 'Compute' section has a 'Compute' button and a 'Compute details' section with a 'Contact/collision threshold' set to 0.1 Model unit and a 'Compute clash for' dropdown set to 'Saved selection sets'. The 'Visualization' section has a 'Show clash by' dropdown set to 'Selection', a 'Zoom fit' checkbox checked, and a 'Clash pair transparency' slider set to 50.

The 'Output' window at the bottom shows the following text:

```
Parser started reading C:\Program Files\Kisters\ViewStation\3DVS_samples\micro engine.CATProduct.3dvs 12:53:04
### This 3dvs was created with a development version ###
Loading Tessellation
Loading BREP
Finished loading geometry 12:53:04 - Load time: 00:00:00
Parser finished 12:53:04 - Load time: 00:00:00
WARNING: Clash detection target mode is switched to single parts because there are less than 2 stored selection sets.
```



2.21 Band Analysis







This functionality is available **from version 2020.1**.

► Toolpane Settings

This chapter describes the tool settings of the Band Analysis function.

Setting / Button	Default value (If multiple options are available, the default is bold.)	Description
Band analysis		
Accuracy	5.0 mm	Defines the accuracy of the calculation. Reducing the value provides more accurate results, but increases the calculation time.
Compute		Starts a distance band calculation. Settings below can be changed before and after the calculation.  A new calculation will overwrite the color map values, if "Freeze min/max values" is off.
Visualization		
Limit values to min/max		Off: Values above the maximum or below the minimum values of the defined "Color map" will be shown in the color defined by "Outside min/max color". On: The color of the minimum or maximum value will be assigned to the values outside the color map range.
Outside min/max color		This color will be assigned to values outside the "Color map" range, if setting "Limit values to min/max" is off.
Freeze min/max values		Off: New calculations will overwrite the "Color map" values. On: Color map values will be kept for new calculations.
Color map presets		Presets that contain predefined colors and the "Number of values" for the "Color map". Shows "User defined" when no preset matches the "Color map" settings chosen.  Presets can be adjusted and added: Installation directory\Resources\presets.xml.
Reverse colors		On: Reverses the color sequence of the "Color map".
Relative values		Off: Show "Color map" values as absolute distances. On: Show color map values as intervals.
Color map		
Number of values		Number of values and colors.  Changing the number will trigger a recalculation of the intermediary values and colors.
Reset		Resets all "Color map" values to the min/max values of the calculation.

Setting / Button	Default value (If multiple options are available, the default is bold.)	Description
min/max		 Ignores "Freeze min/max values".
Value automation		
Update intermediate values		Interpolates the intermediate values of the color map.  Helpful after editing the min/max values of the color map.
Apply quantiles		Removes outlying values from the color map. The top and bottom 5 % of values are ignored to focus on the values in the middle.
Apply logarithmic scale		Uses a logarithmic scale on the color map.  Sometimes linear intervals obscure very small but important value ranges that are close together. This spreads those small ranges and assigns them a larger color spectrum, making them more expressive.
Miscellaneous		
Apply selection to others		Color map results with different settings cannot be meaningfully displayed in the legend. This applies the settings of the selected result to all other visible results and updates the color map and legend accordingly.
Create band geometry		Converts the shown visualization of bands to individual geometries per color band. These geometries can be exported.
Unify properties		If two or more heatmap nodes (of the same type) with different visualization properties are selected, they have to be unified before we can display the visualization settings.
Legend		
Show histogram	false	On: Color legend shows a dotted line indicating the frequency distribution of the values.
Number of decimal places	4	Specifies the displayed decimal places of the color map values.
Show equidistant values	false	Off: All legend intervals are spaced according to their numeric value. On: All legend intervals are spaced with equal distances, irrespective of their numeric values.

Setting / Button	Default value (If multiple options are available, the default is bold.)	Description
		 This improves visibility for very small intervals.

► Tutorial

The band analysis colours segments of parts according to the minimum distances between these parts.

- Open the 3D model from the following folder: <Installation folder 3DViewStation>/Samples/micro_engine.CATProduct.3dvs
- Isolate the **HOUSING** and the **CARBURETOR** geometry in the structure area.
- Activate the **ANALYZE** tab in the function area.

- Select the **BAND ANALYSIS**  function from the **CLEARANCE** function group.
- Click on **[COMPUTE]**.

Red indicates the areas with the smallest distance to each other (less than 6.8 mm distance).

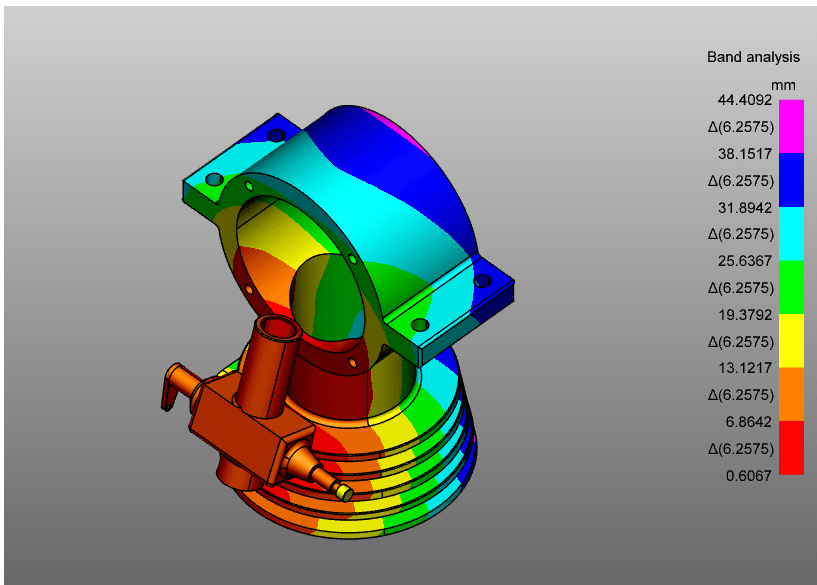

In this example, we are trying to find out which areas have a distance < 2.5 mm.

- To do this, change the first value in the color map to 2.5.

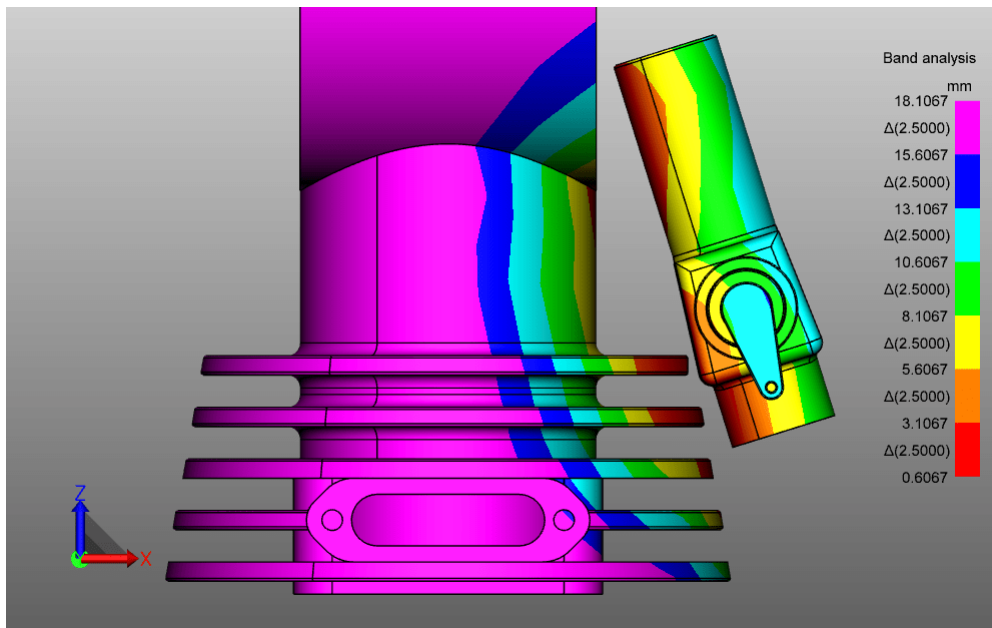

Tip

- If the **RELATIVE VALUES** option is enabled, you can change the first value of the **COLOR MAP**, and the other values will automatically change to that value as well.
- If you have already set the color table values you are interested in, activate **FREEZE MIN/MAX VALUES** to prevent overwriting during calculation.
- Turn on **SHOW HISTOGRAM** to see the distribution of values.
- The difference between selected and unselected color map node: brighter colors.
- Changes to the visualization and legend settings are only applied to already created color map nodes if they are selected.

► Blog post

The following video demonstrates the Curvature Analysis feature and the advanced color maps (heatmaps) for viewing certain results of the advanced 3D functions such as Wall Thickness and Band Analysis.



[Link to the blog post](#)



2.22 Curvature Analysis



This functionality is available **from version 2023.x**.

► Toolpane Settings

This chapter describes the tool settings of the Curvature Analysis function.

Setting / Button	Default value (If multiple options are available, the default is bold.)	Description
Compute		Starts a curvature calculation. Settings below can be changed before and after the calculation.  A new calculation will overwrite the color map values, if "Freeze min/max values" is off.
Visualization		
Curvature type	<ul style="list-style-type: none"> ▪ Gaussian ▪ Mean ▪ Maximum 	Choose the type of the curvature analysis to be displayed. Each curvature point has a minimum and a maximum curvature value and those can be interpreted differently: - GAUSSIAN: The product of both curvature values is used to detect surfaces curved on both sides (extreme or saddle points). - MEAN: Arithmetic mean of minimum and maximum curvature values. Helps to identify surfaces with abrupt curvature change. - MAXIMUM: Displays the maximum curvature values. Helps identify problematic surfaces for milling and toolpath planning.
Use absolute value		Off: Use positive and negative values of the curvature calculation for the display of the color map. Turn off when using "Gaussian" type. On: Instead use the absolute values.
Limit values to min/max		Off: Values above the maximum or below the minimum values of the defined "Color map" will be shown in the color defined by "Outside min/max color". On: The color of the minimum or maximum value will be assigned to the values outside the color map range.
Outside min/max color		This color will be assigned to values outside the "Color map" range, if setting "Limit values to min/max" is off.
Outside min/max transparent		Off: Show values outside of the color map value range in the color defined with "Outside min/max color". On: Values are hidden, if they are outside of the color map min/max values.
Freeze min/max values		Off: New calculations will overwrite the "Color map" values. On: Color map values will be kept for new calculations.
Color map presets		Presets that contain predefined colors and the "Number of values" for the "Color map". Shows "User defined" when no preset matches the "Color map" settings chosen.  Presets can be adjusted and added:

Setting / Button	Default value (If multiple options are available, the default is bold.)	Description
		Installation directory\Resources\presets.xml.
Reverse colors		On: Reverses the color sequence of the "Color map".
Show color bands		Off: Shows a gradient transition between colors on the geometry and in the legend. On: Shows color bands instead.
Color map		
Number of values		Number of values and colors. i Changing the number will trigger a recalculation of the intermediary values and colors.
Reset min/max		Resets all "Color map" values to the min/max values of the calculation. i Ignores "Freeze min/max values".
Value automation		
Update intermediate values		Interpolates the intermediate values of the color map. i Helpful after editing the min/max values of the color map.
Apply quantiles		Removes outlying values from the color map. The top and bottom 5 % of values are ignored to focus on the values in the middle.
Apply logarithmic scale		Uses a logarithmic scale on the color map. i Sometimes linear intervals obscure very small but important value ranges that are close together. This spreads those small ranges and assigns them a larger color spectrum, making them more expressive.
Miscellaneous		
Apply selection to others		Color map results with different settings cannot be meaningfully displayed in the legend. This applies the settings of the selected result to all other visible results and updates the color map and legend accordingly.
Unify properties		If two or more heatmap nodes (of the same type) with different visualization properties are selected, they have to be unified before we can display the visualization settings.

Setting Button	Default value (If multiple options are available, the default is bold.)	Description
Legend		
Show histogram	false	On: Color legend shows a dotted line indicating the frequency distribution of the values.
Number of decimal places	4	Specifies the displayed decimal places of the color map values.
Show equidistant values	false	Off: All legend intervals are spaced according to their numeric value. On: All legend intervals are spaced with equal distances, irrespective of their numeric values.  This improves visibility for very small intervals.

► Tutorial

If no values are defined in the **COLOR MAP**, they are automatically filled with the minimum and maximum values of the selected **CURVATURE TYPE** calculation.

Maximum

Use the Maximum curvature type to find surfaces that may be difficult for milling/toolpath planning.

- Open the 3D model from the following folder: <Installation folder 3DViewStation>/Samples/micro_engine.CATProduct.3dvs
 - Isolate the **HOUSING FRONT** geometry in the structure area.
 - Activate the **ANALYZE** tab in the function area.
 - Select the **CURVATURE**  function from the **MOLD** function group.
 - Select **MAXIMUM** from the curvature types.
 - Click on **[COMPUTE]**.
- Blue to purple indicate the problematic areas.

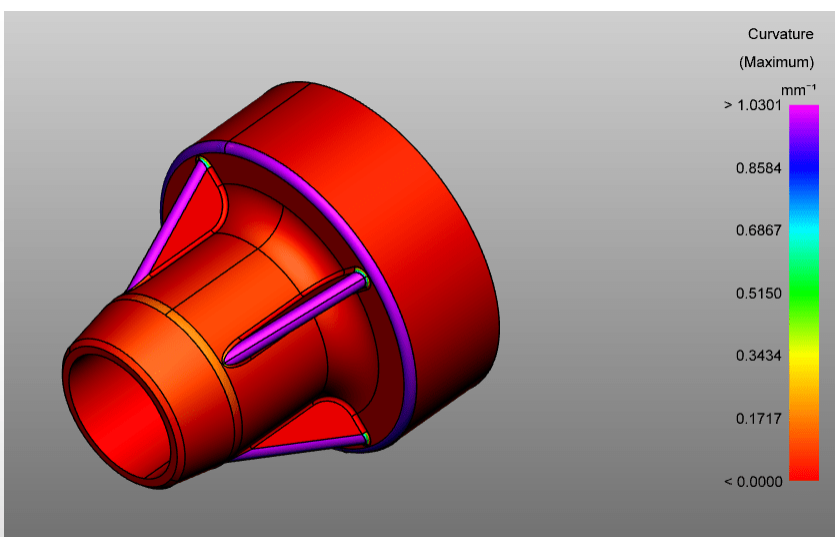

Gaussian

Use the Gauss curvature type to find extreme or saddle points on surfaces.

- Open the 3D model from the following folder: <Installation folder 3DViewStation>/Samples/micro_engine.CATProduct.3dvs
- Isolate the **HOUSING FRONT** geometry in the structure area.
- Activate the **ANALYZE** tab in the function area.
- Select the **CURVATURE**  function from the **MOLD** function group.
- Select **GAUSSIAN** from the curvature types.
- Click on **[COMPUTE]**.
- Deactivate the **USE ABSOLUTE VALUE** setting.
The extreme and saddle points are already visible.

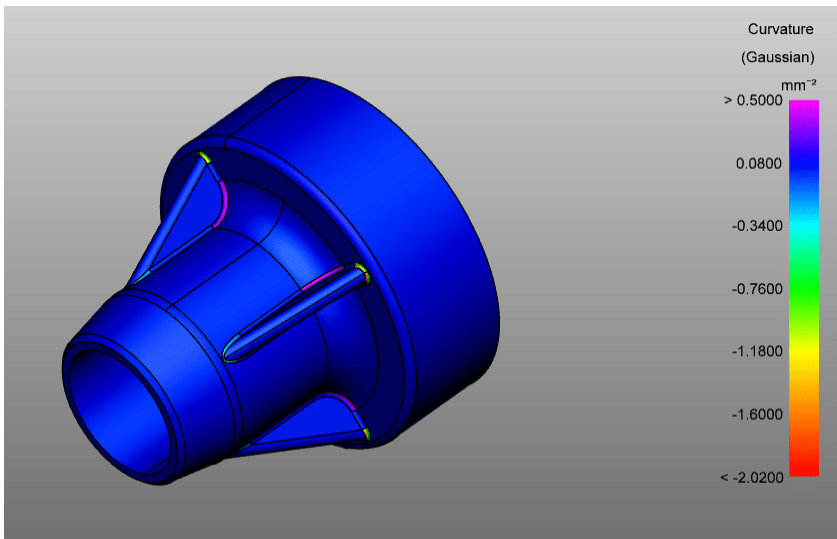

For a better visualization, click **APPLY QUANTILES**.

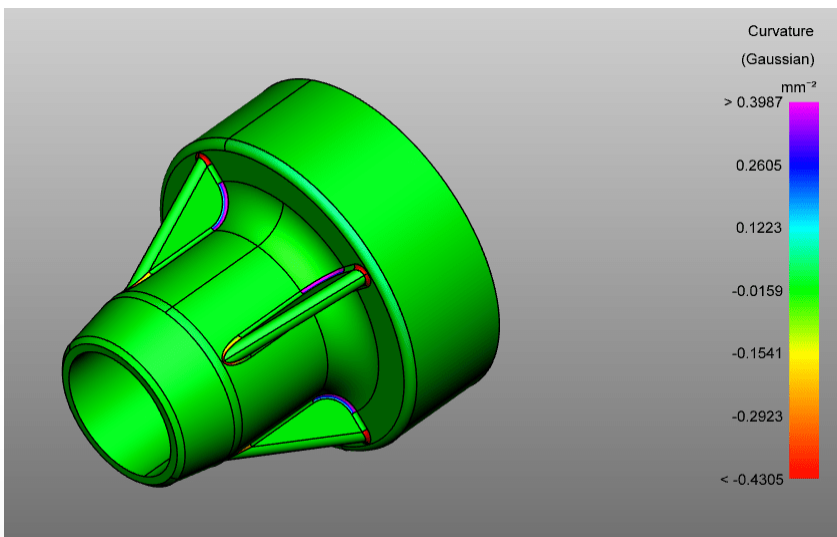

Mean

Use the Mean curvature type to detect abrupt curvature changes.

- Open the 3D model from the following folder: <Installation folder 3DViewStation>/Samples/micro_engine.CATProduct.3dvs
- Isolate the **HOUSING FRONT** geometry in the structure area.
- Activate the **ANALYZE** tab in the function area.
- Select the **CURVATURE**  function from the **MOLD** function group.
- Select **MEAN** from the curvature types.

- Click on **[COMPUTE]**.
The higher the values, the more the curvature changes - purple areas.

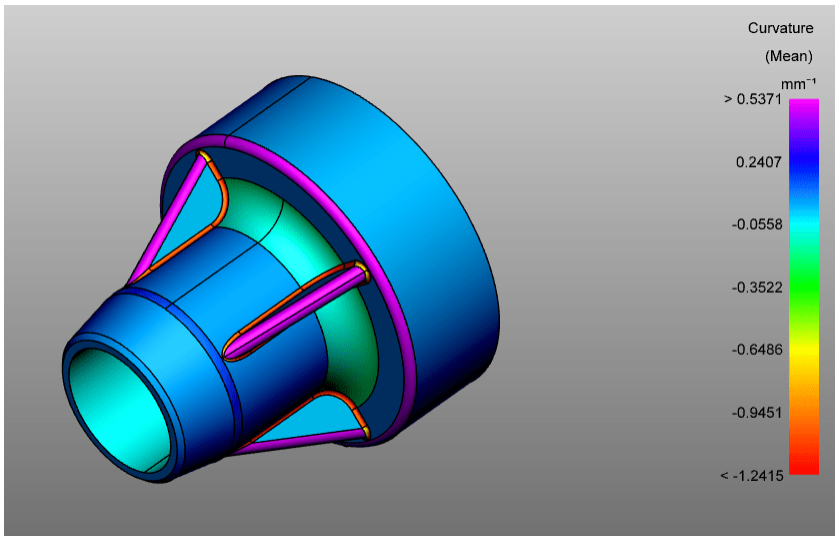

Tip

- If you have already set the color table values you are interested in, activate **FREEZE MIN/MAX VALUES** to prevent overwriting during calculation.
- Turn on **SHOW HISTOGRAM** to see the distribution of values.
- The difference between selected and unselected color map node: brighter colors.
- Changes to the visualization and legend settings are only applied to already created color map nodes if they are selected.

► Blog post

The following video demonstrates the Curvature Analysis feature and the advanced color maps (heatmaps) for viewing certain results of the advanced 3D functions such as Wall Thickness and Band Analysis.



[Link to the blog post](#)

2.23 Transformations (Move, Rotate, Mirror and Explode)

► Toolpane Settings

This chapter describes the tool settings of the Transformation functions.

Setting / Button	Default value (If multiple options are available, the default is bold.)	Description
Aligning transformation		
Show preview		On: Shows preview of the transformation.
Preview transparency		Transparency of the preview.
Create copy		On: Instead of transforming the selected parts to the destination, a copy will be created.
Mode	<ul style="list-style-type: none"> ▪ Interactive ▪ Opposed ▪ Aligned 	Choose the alignment mode: <ul style="list-style-type: none"> - Interactive: moving the mouse toggles between "opposite" and "aligned". By a left click the displayed preview is applied. - Opposed: the preview is displayed opposite to the target geometry and cannot be changed via mouse. - Aligned: the preview is placed in the target geometry and cannot be changed via mouse.
Offset		Defines offset to the transformation.
Boundary condition		
Active		On: Activate boundary condition.
Boundary condition	<ul style="list-style-type: none"> ▪ Line ▪ Circle axis ▪ X axis ▪ Y axis ▪ Z axis ▪ Local X axis ▪ Local Y axis ▪ Local Z axis ▪ Last used 	Sets the type of boundary condition. "Line" and "Circle Axis" require a selection by clicking in the scene. Afterwards the entry will change to "Last used". "Last used" means that the boundary condition of a previous "Transformation" or "Alignment" is active. "X axis", "Y axis" and "Z axis" use the respective axes of the activated coordinate system of the scene. The "Local" axes refer to the coordinate system of the selected geometry. If multiple geometries are selected, the activated coordinate system of the scene will be used at the bounding box center of the selected geometries.

► Tutorial

Make sure to familiarize yourself with the relevant chapters [Object Selection](#)^[23] and [Saving Selections](#)^[24], because all the transformations described in the following chapter are done for a selection.

You have several options for transforming objects:

- Transformation via Auxiliary Objects (Handles)
- Transformation by way of value entry
- Transformation with boundary conditions
- Transformation via reference objects

Transformation via Auxiliary Objects (Handles)

- Select the object(s) of interest via mouse click (if necessary with multiple selection using the keys [CTRL] or [⇧]) in the model area or via the structure.
- Enable the relevant transformation function via its button in the **TRANSFORMATIONS** tab.

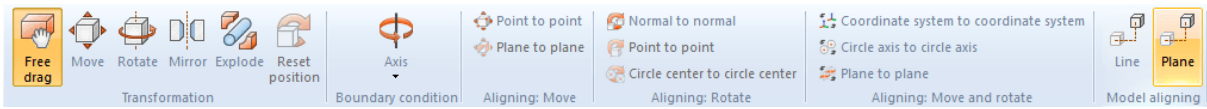

- Click the handles and move the cursor to move or rotate objects directly in the model area. The **FREE DRAG** function allows the repositioning of an object via drag & drop. The object is moved within the level currently selected as the model view.
- Exit the transformation function by clicking the same button again within the function area or by pressing [ESC].
- Clicking the **[RESET POSITION]** button returns the object to its original position. Each individual transformation step can be reversed by clicking **UNDO** in the **START** ribbon.

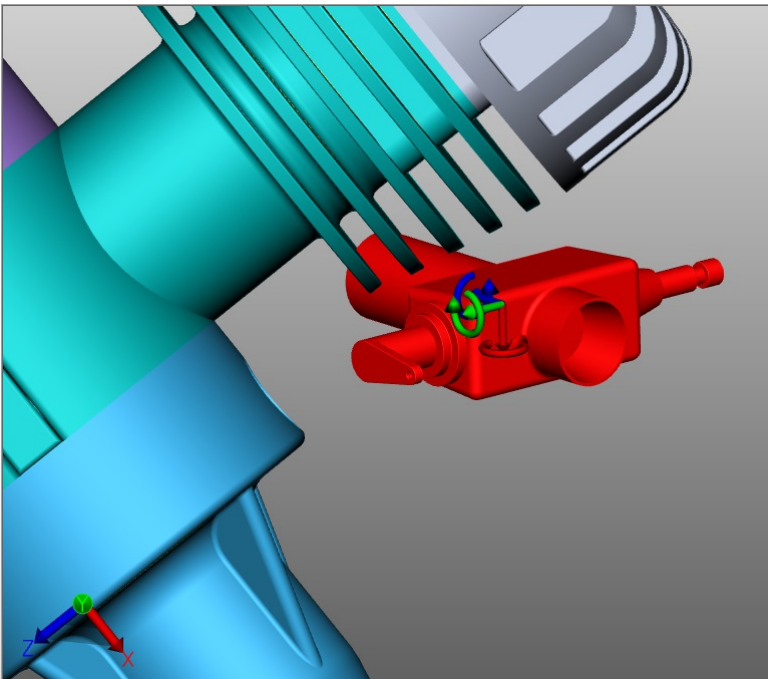
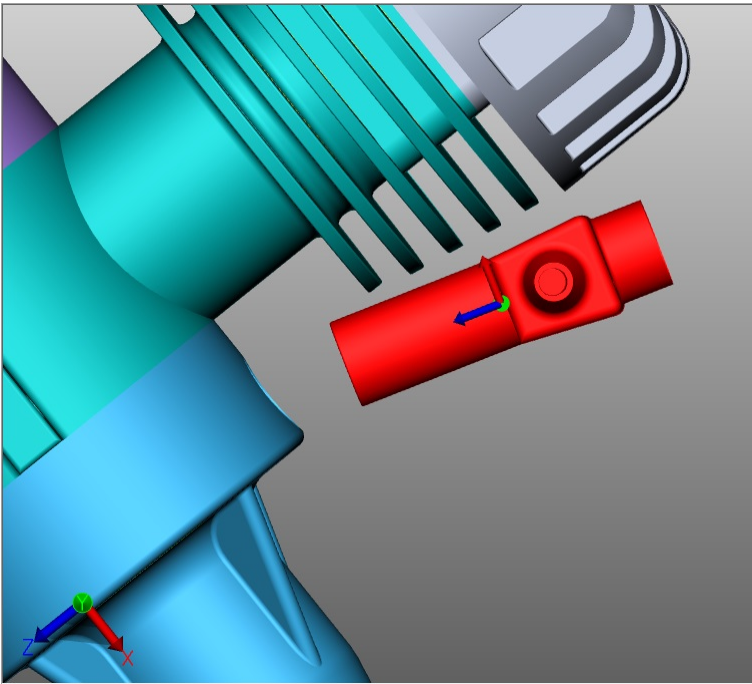

Transformation by way of value entry

Initiate **FREE DRAG**, **MOVE**, **ROTATE** or **SCALE**, as described in the section above. The tools pane appears, where the following options are provided for the exact change in position:

Transformation via the input of position coordinates

You will find the coordinates of your current selection under **POSITION BOUNDING BOX CENTER**. If you change the coordinates here, the selection is moved to the corresponding new position.

Transformation via the input of move values

A selection can also be moved in relation to the current position. This translation is the offset to the initial position. That means on the one hand that the selection will be reset to the initial position when the value **[0]** is entered, and on the other that various values can be tried out without having to compute previous entries. The values entered, as well as the initial position will remain intact until: the selection is deselected, a transformation is executed via the handles, or a value is entered under Rotation.

Entering rotation angle values

Just like for a translation, an angle value can be entered for **ROTATION** to rotate the current selection on the relevant axis. The rotation axis passes through the bounding box center, unless boundary conditions were specified.

Changing the model size

Under the item **SCALE** the size of the selected object can be changed. To do this, enter the percentage size in the **tool area**  under **SCALING > SCALE TO**.

Create offset lines

Translations can be visualized via offset lines.

- To do this, activate the **CREATE OFFSET LINE** toggle in the tool area.
- Adjust the **LINE TYPE**, **PATH TYPE** and **COLOUR** if necessary.
- Use the **FREE DRAG** or **MOVE** transformation function to move the desired objects out of the assembly.
- Click the **DELETE OFFSET LINES** button in the Tool Area to remove the created offset lines.

Transform	
Position bounding box center	
X	58.32 mm
Y	27.76 mm
Z	-25.91 mm
Translation	
X	0.0 mm
Y	0.0 mm
Z	0.0 mm
Rotation	
X	0.0°
Y	0.0°
Z	0.0°
Offset line	
Create offset line	<input type="checkbox"/>
Path style	Automated
Dash style	---
Color	R: 51, G: 51, B: 51

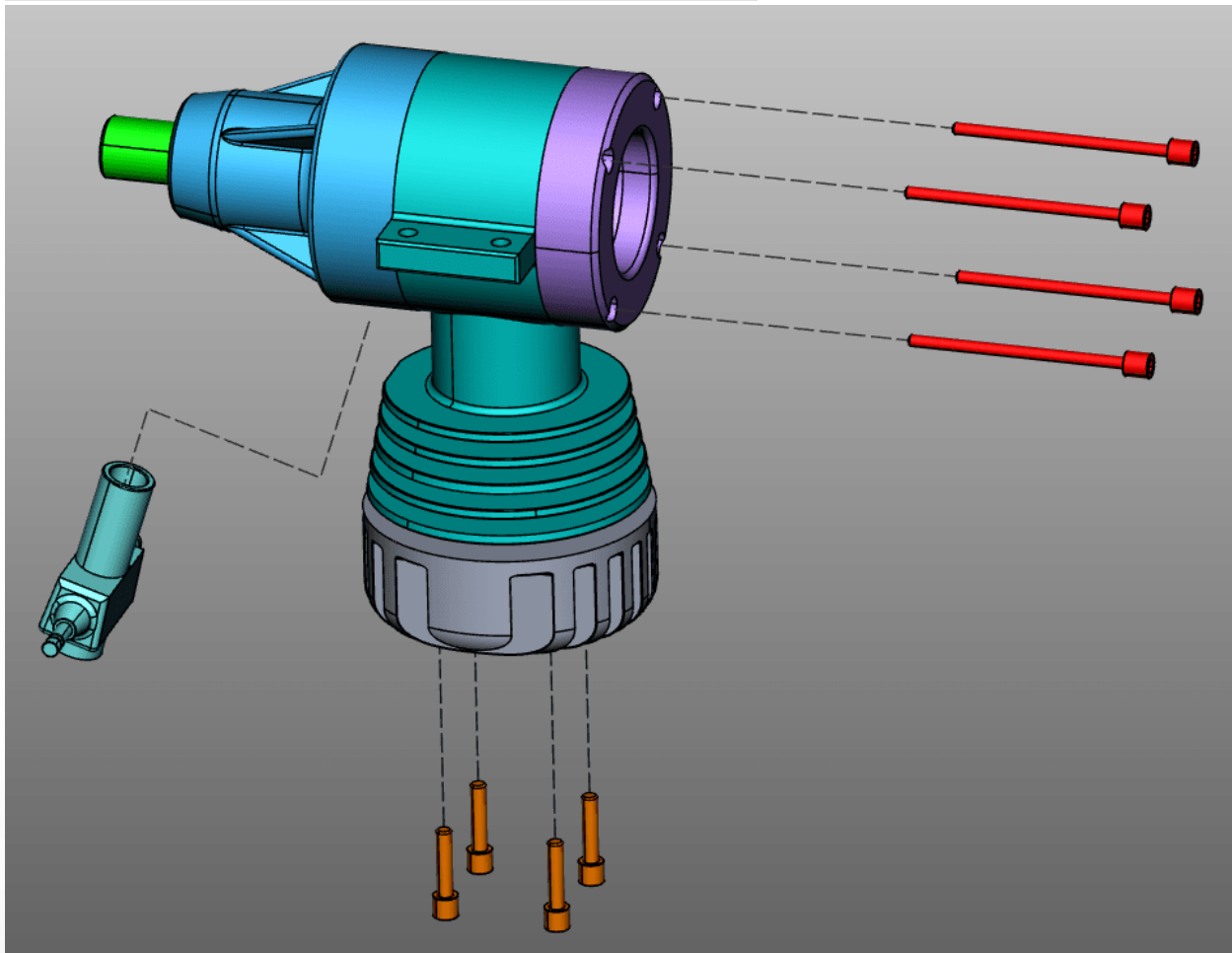

Boundary Conditions

Boundary conditions allow the limitation of transformations to specified axes. This function is particularly useful for transformations via reference points. Boundary conditions can be lines, e.g. at edges of geometries, circular axes or the axes of the coordinate system.

- Choose a type for the boundary condition: **LINE**, **CIRCLE AXIS**, **X-AXIS**, **Y-AXIS** or **Z-AXIS**. In this example, the boundary condition circle axis is used.
Note: If you select one of the xyz axes as boundary condition, the corresponding xyz axis of the world coordinate system is used as boundary condition. However, if you use a custom coordinate system, the corresponding xyz axis of that coordinate system will be used. See chapter [Generate Coordinate System](#)

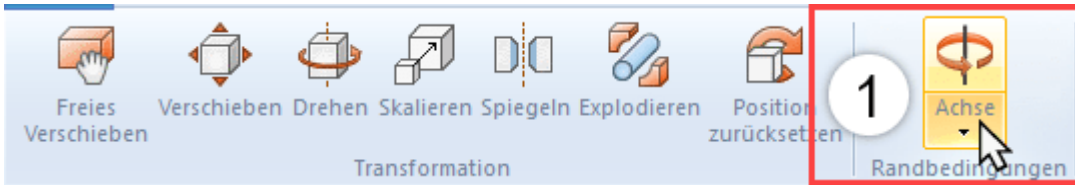

- Move the cursor over a geometry. Possible positions for boundary conditions are highlighted.

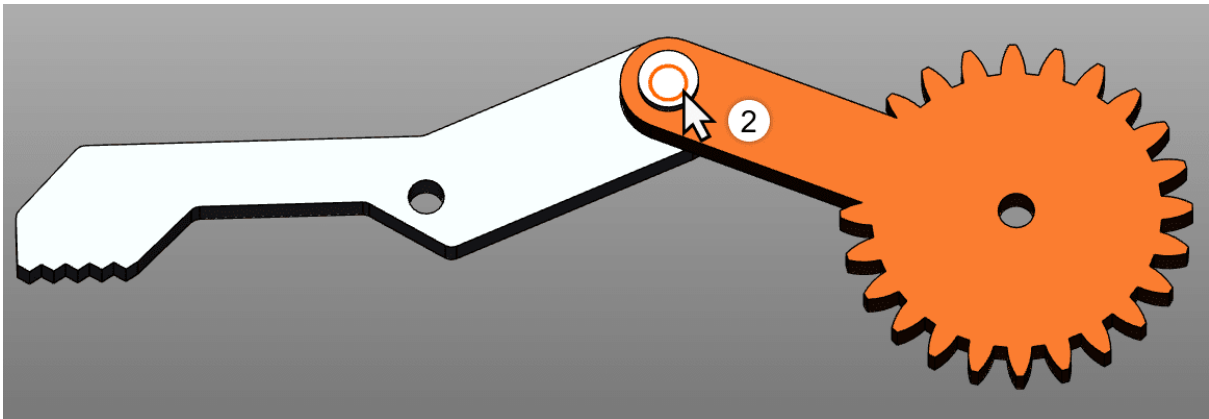

- Left-click a position to confirm.
- The selected boundary condition is activated and is visualized in the 3D scene by an orange auxiliary geometry; additionally, the button **[BOUNDARY CONDITION]** axis is now highlighted.

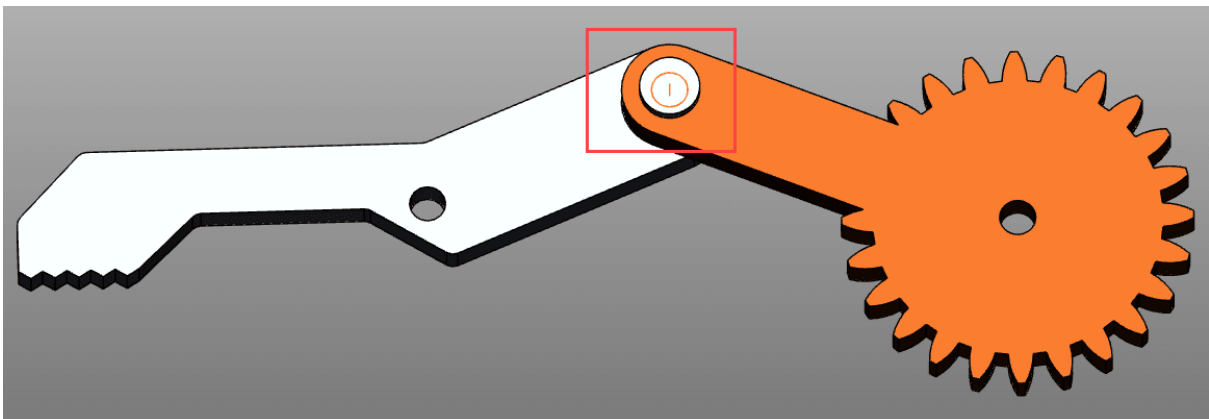

- Select the desired transformation mode.

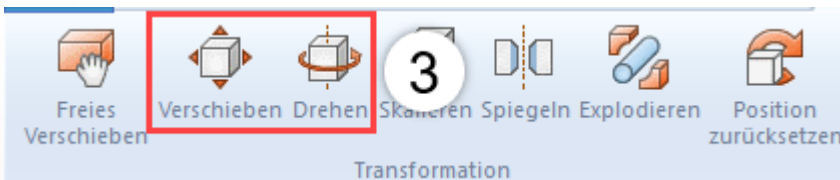

- Select the object(s) you want to move or rotate around the boundary condition.
- If now, as described above, a displacement or rotation is performed, this is only possible along the boundary condition just set.

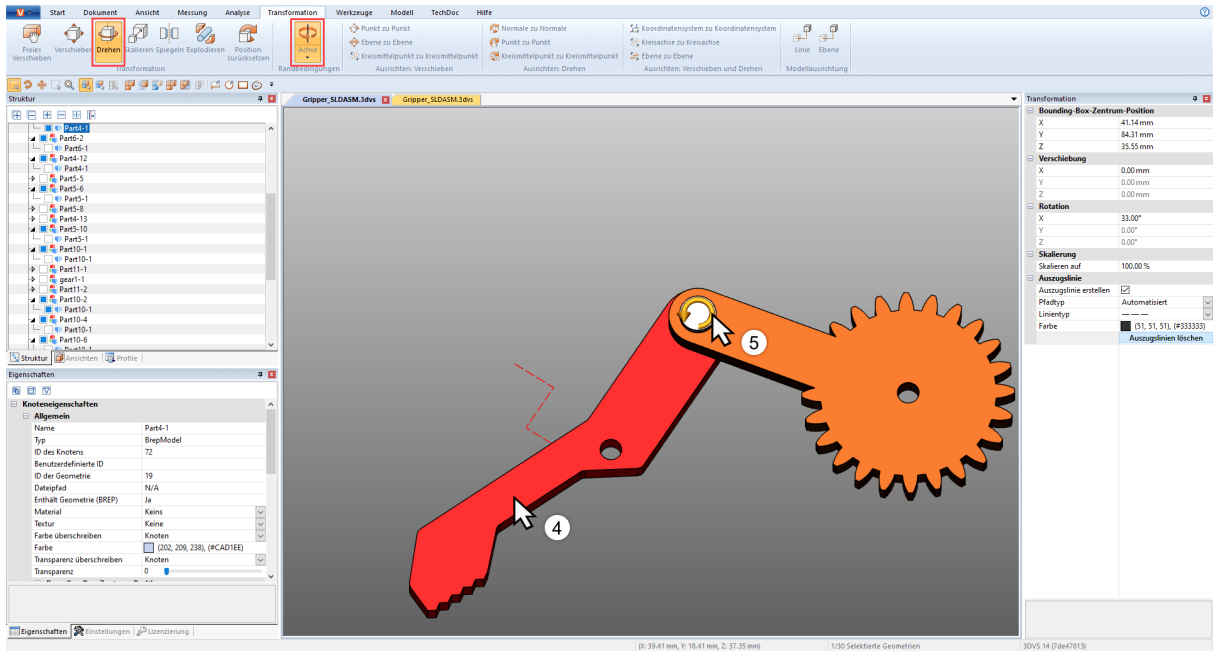

Transformation via reference points

You have several options for transforming objects via reference points. These are divided into three categories for a better overview: Move, Rotate as well as Move and Rotate. Some of these transformations will require an active boundary condition (see above).

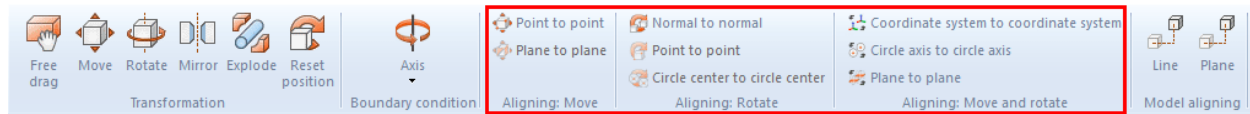

Move

This category contains only functions for moves without rotation.

Point to Point Translation

- As a first step, select the parts you wish to move.
- Select the **POINT TO POINT** function.
- Select any starting point for the move. Lines, edges, corners, coordinate systems, etc. will be captured to place the exact initial position. Generally, you will first have to select a point on the selected object to achieve the expected transformation.
- Select the end point for the move.
- The selection will now be translated in such a way as to position the selected points congruently without any rotation.

Plane to Plane Translation

- Choose a type for the boundary condition: Line or circle axis.
- As a first step, select the parts you wish to move.
- Select the **PLANE TO PLANE** function.
- Select a plane on the part you want to translate.
- Select the target plane for the move.

Translation from circle center to circle center

- As a first step, select the parts you wish to move.
- Select the **CIRCLE CENTER TO CIRCLE CENTER** function.
- Select a circle on the part you want to translate.

Translation from circle center to point

- As a first step, select the parts you wish to move.
- Select the **CIRCLE CENTER TO POINT** function.
- Select a circle on the part you want to translate.
- Select the point to which you want to translate the selection
- The selection is now translated so that the center of the circle and the point are congruent.

Rotate

This category contains only functions for rotations without translation.

Normal to Normal

This function allows you to align objects along the normal of areas, e.g. to position two areas in parallel.

- As a first step, select the object you want to rotate.
- Select the **NORMAL TO NORMAL** function.
- Click the area for which you want to align the normal. Generally, you will first have to select an area on the selected object to achieve the expected transformation.
- Now click the area to the normal of which you want to align the normal specified in point 3.
- The selected areas will now be positioned in parallel.

Point to point

A boundary condition must be set first in order to use this transformation. You can then use this function to rotate objects based on two points around the axis defined by the boundary condition.

- Specify a boundary condition as described above.
- As a first step, select the parts you wish to move.
- In the category **ROTATE**, select the function **POINT TO POINT**.
- Select any starting point of the rotation. Lines, edges, corners, coordinate systems, etc. will be captured to place the exact initial position. Generally, you will first have to select a point on the selected object to achieve the expected transformation.
- Select the end point for the rotation.
- The object is now rotated around the previously defined boundary condition so that the points are positioned as congruently as possible or at the least possible distance from each other.

Circle Center to Circle Center

A boundary condition must be set first in order to use this transformation. You can then use this function to rotate objects based on two circle centers around the axis defined by the boundary condition.

- Specify a boundary condition as described above.
- As a first step, select the parts you wish to move.
- In the category **ROTATE**, select the function **CIRCLE CENTER TO CIRCLE CENTER**.
- Select any circle as starting point for the rotation. Generally, you will first have to select a circle on the selected object to achieve the expected transformation.
- Select a circle as the end point of the rotation.
- The object is now rotated around the previously defined boundary condition so that the circle centers are positioned as congruently as possible or at the least possible distance from each other.

Move and Rotate

This category contains functions that allow a move and rotation simultaneously.

Coordinate System to Coordinate System

You should familiarize yourself with the [creation of coordinate systems](#)  before you use the function for the transformation from coordinate system to coordinate system.

- As a first step, select the parts you wish to align. The initial coordinate system can be part of that selection.
Note: The boundary conditions must be deactivated.
- Select the "Coordinate system to coordinate system" function.
- Select the initial coordinate system for the translation in the 3D scene (usually part of the selection).
- Select the target coordinate system for the translation in the 3D scene.
- Your selection will be translated from the initial coordinate system to the target coordinate system in such a way that the two coordinate systems are congruent.

Circle Axis to Circle Axis

This function allows a positioning of your selection via circles.

1. As a first step, select the parts you wish to align.
2. Select the **CIRCLE AXIS TO CIRCLE AXIS** function.
3. Select any circle as starting point of the transformation. Generally, you will first have to select a circle on the selected object to achieve the expected transformation.
A successfully defined initial circle will be highlighted in orange. This circle will also contain a drawn coordinate system. Take note of the position of this coordinate system in relation to the circle axis for step 5.
4. Select another circle to which the previously selected circle is to be translated. Once the target circle is specified, it too will be highlighted in orange and it too will contain a drawn coordinate system.
5. You now have to specify the alignment to complete the transformation. Move the cursor to one or the other side of the target circle. The coordinate system preview on the circle axis will follow the cursor. Left-click to specify the alignment and complete the transformation.
6. The selection will now be transformed in such a way that the circles are positioned congruently, taking into account the orientation of the coordinate systems.

Reflection

1. Select the object to be mirrored.
2. Enable the **MIRROR** function via the button in the **TRANSFORMATIONS** tab.
3. Select the mirror plane in the tool pane menu.
4. Mark the checkbox **CREATE COPY** to generate a new mirrored object instead of mirroring the original object. Objects created via the Mirror function will be saved under the structure node CreatedNodes/MirrorGeometrySet.
5. Click the **MIRROR** button in the tool pane. In the illustration below, the object was subsequently moved.

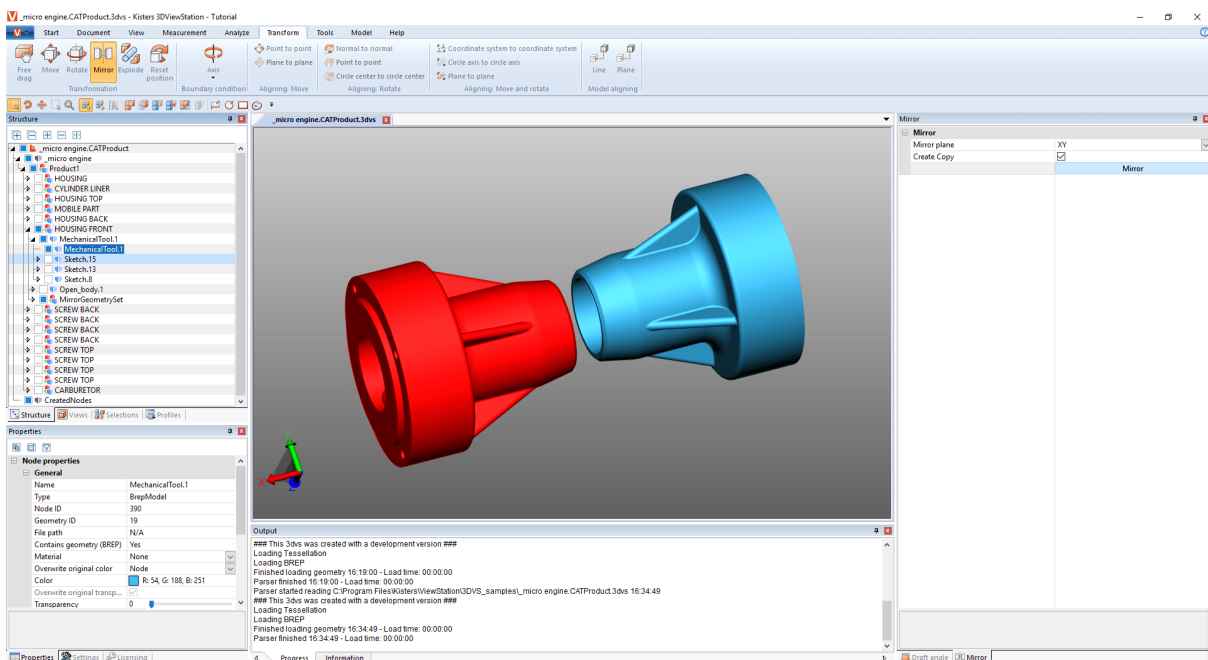

Explode

The function **EXPLODE** allows you to move the individual parts of the model from the center to the outside. You can specify whether the hierarchy planes of the structure should be included.

1. Enable the **EXPLODE** function via the button in the **TRANSFORMATIONS** tab.
2. If you want to include the hierarchy planes of the structure when exploding, mark the **EXPLODE HIERARCHICALLY** option and activate, if necessary, the **OFFSET LINES** function.
3. Use the slider to set the desired explosion level or enter it manually. The result is displayed immediately.

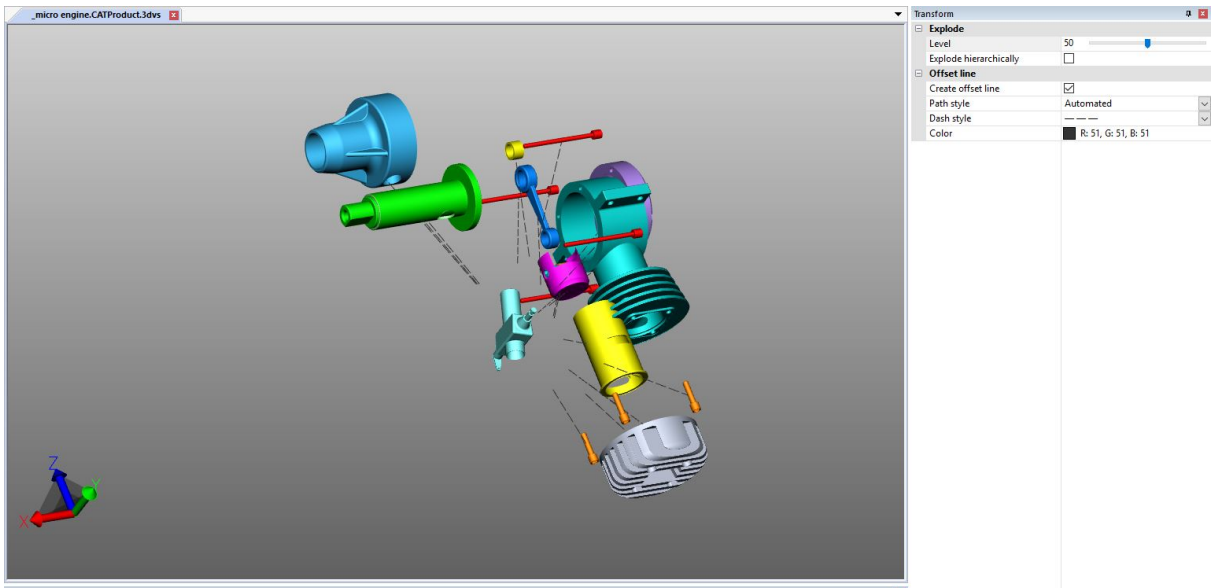

Reset Position

Any transformed parts can be reset to their original position. Select one or more parts and click the button **[RESET POSITION]**.

Model Aligning

Several imported parts or assemblies can be aligned in one line or on one plane by clicking the relevant button. These functions are not available for selections.

2.24 Annotations / Markups

The following 3D markup tools are available to attach annotations in the model area: **TEXT**, **CIRCLE**, **RECTANGLE** and **FREEHAND**. These can be stored as a view [\[32\]](#).

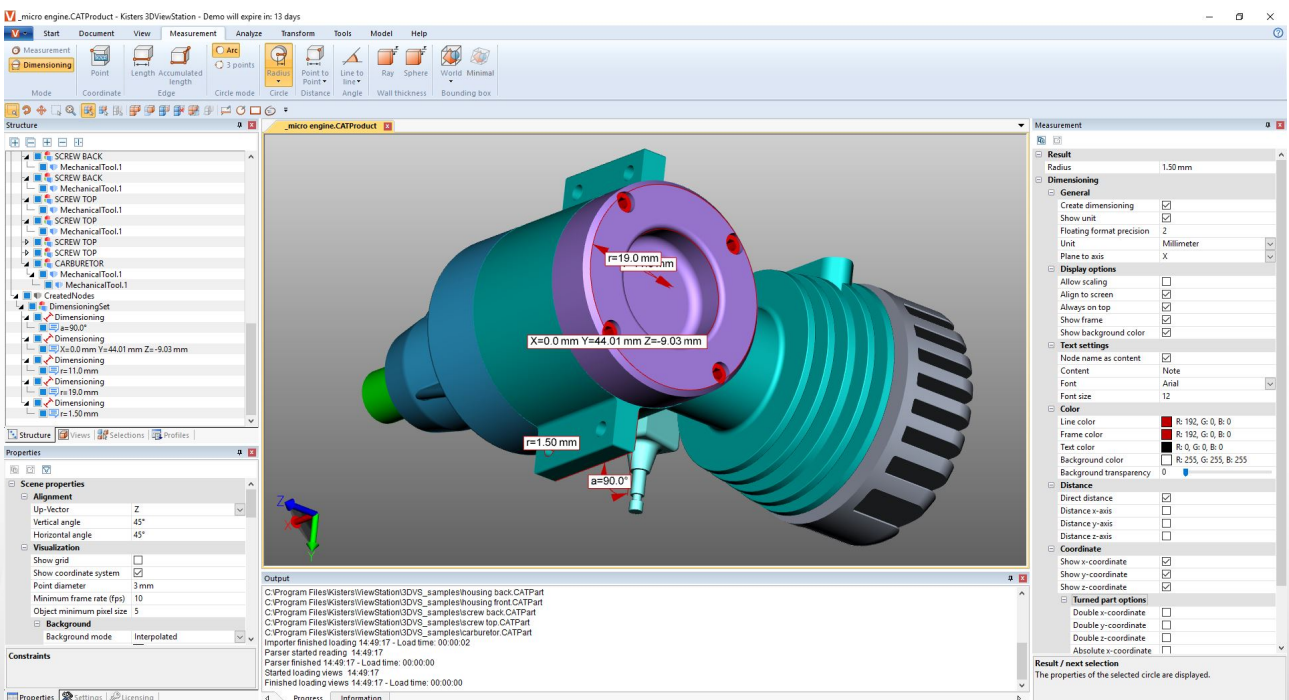

The following steps are required to add annotations in the model area:

- Enable the desired function in the **3D MARKUP** area of the **TOOLS** tab.
- Attributes like color can be configured in the **MARKUP** tool pane before generating the 3D markups. End the currently selected function first if you want to edit existing markups. Then you can select, delete or edit the desired object as usual in the properties pane.
- Left click the model area to specify the start point of the 3D markup, hold the button and drag the mouse to the desired end point.
- Circles are drawn from their center point.
- Text markups must be generated on a geometry.
- The text container of a text markup can be selected and moved at any time. Please use the **transformation functions** (62) to move an entire markup as well as circles, rectangles and free hand drawings.
- Save a view to store the 3D markups and the view of the model associated with these markups. We recommend creating a view before you start annotating, so that you can return to the status before you applied any markups at any time (see chapter **Customizing the View** (32)).

2.25 Search (Filter)

Proceed as follows to use the filter function to find objects in the model:

1. Activate the **SEARCH** function in the **TOOLS** tab.
 - **SEARCH BY NAME** filters for matches with the names of all objects in the structure.
 - **SEARCH BY PMI, MARKUP, TEXT** searches for matches e.g. in dimensions, callouts and text
 - **SEARCH BY ATTRIBUTE** filters all attributes of all objects. Use only one of the fields or fill out both fields to limit the search results further.
 - **SEARCH BY TYPE** selects all objects of the same type.
 - **SEARCH BY COLOR** selects objects via their color property.
2. Enter a text you want to search for and start the search by pressing the **[ENTER]** button or the **[SELECT]** button.
 - You can use the "*" placeholder for any number of characters and "?" for exactly one character.



To search for objects using their color, first click the **UPDATE** button. A list of colors is displayed for all visible objects. Click on the color to be selected. The number displayed next to the color represents the number of objects of that color.

Multiple selection of colors is possible with **[CTRL]** or **[⇧]**.

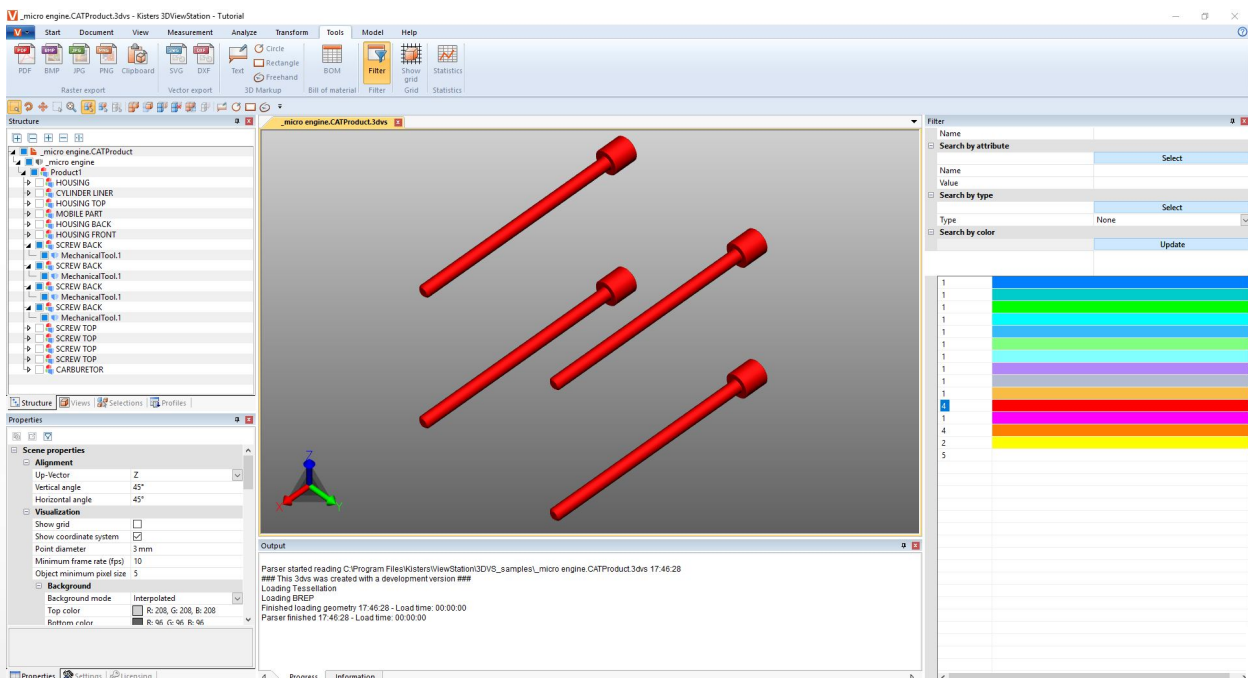
3. The objects found are selected.
4. To display only the found objects in the model area, you can either right click in the model area and select the **ISOLATE** function or use **[ISOLATE]** button on the **START > SELECTION** tab.
5. Close the **FILTER** pane when you no longer need it.



2.26 Technical Documentation (TechDoc) and Bill of Material (BOM)

With this function, you can add **Callouts**  to your model and generate technical documentation from them. The technical documentation can be generated manually or automatically from the **BOM** . You can edit callouts visually and in terms of content using numerous options.

The bill of material can be opened and used without an additional license option via the **TOOLS** tab.

To use the functions in the **TECHDOC** tab, you need a corresponding license option. If you are interested, please contact [our sales department](#).

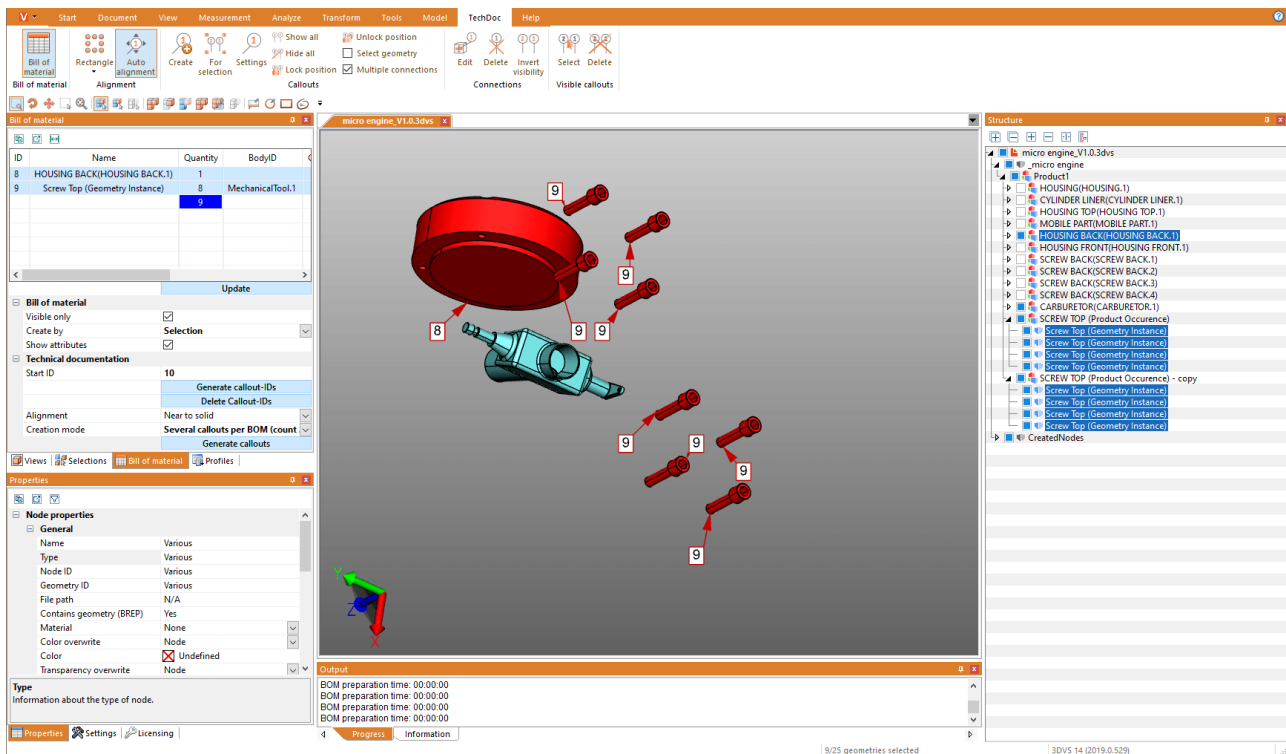

In the next chapters you will learn more about:

- **Create bill of material** 
- **Callouts** 

2.26.1 Create bill of material

A bill of material is a list of parts. It can be created for the entire loaded model or only for visible parts.

To do this, activate the **BOM** function on the **TOOLS** tab.

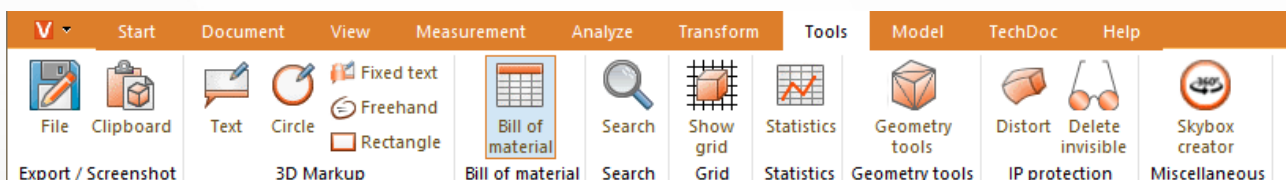

The **BOM** tool window opens in the left structure area of the 3DViewStation as a subtab.

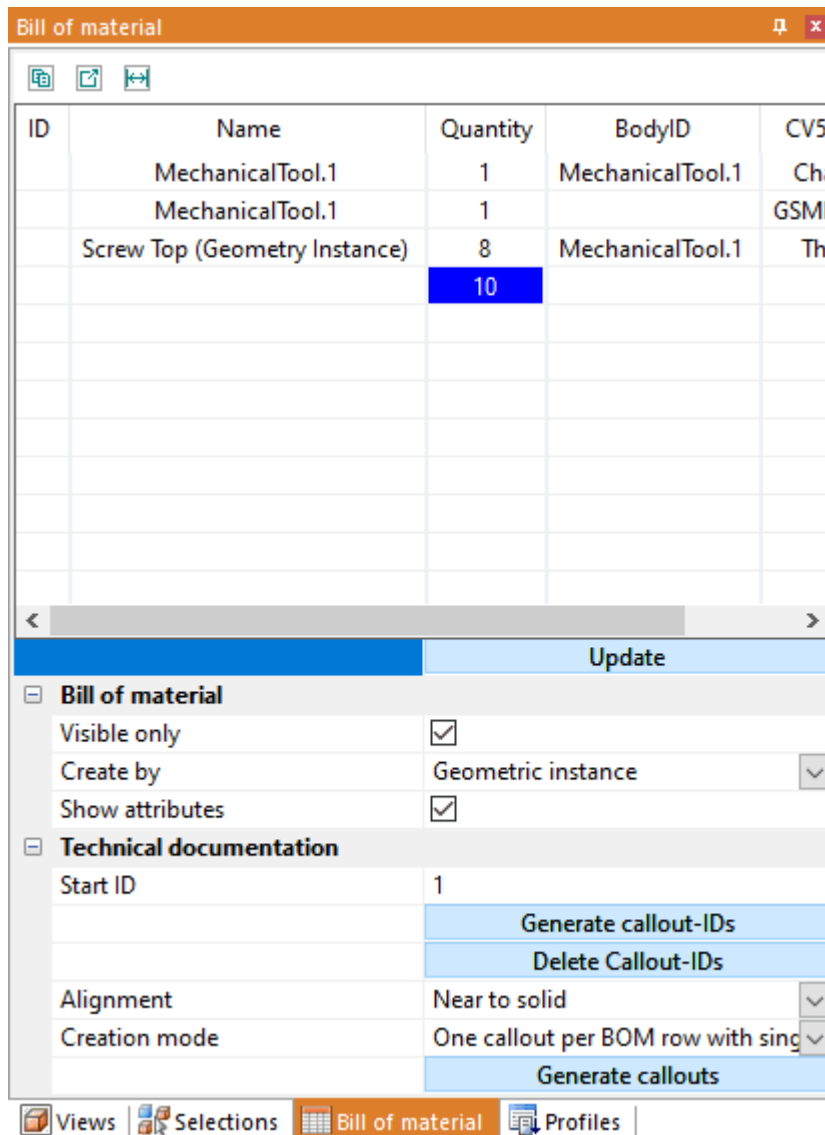

The referenced geometries can be selected via the bill of material. Accordingly, all parts selected by you in the model are highlighted in the bill of material. You can add attributes to the bill of material using the **SHOW ATTRIBUTES** setting. The small buttons below the title bar of the BOM window can be used to export a created bill of material to the clipboard (📄) or to a CSV file (📄). You can define the desired separators in the settings; see chapter [Settings](#) [18].

The bill of material can be created using the references described below.

Note the following:

- For a better overview, the structure window was attached to the right edge of the screen; see ch. [User Interface Concept](#) [7] and [Customizing the Interface](#) [10].
- In order to display the respective properties, the counted layers were selected for the images in this chapter. This is not necessary for the creation of the BOM about geometric instance and product occurrence.

Geometric instance

This bill of material contains the number of all geometric instances (lowest structure level, e.g. type **BREPMODEL**).

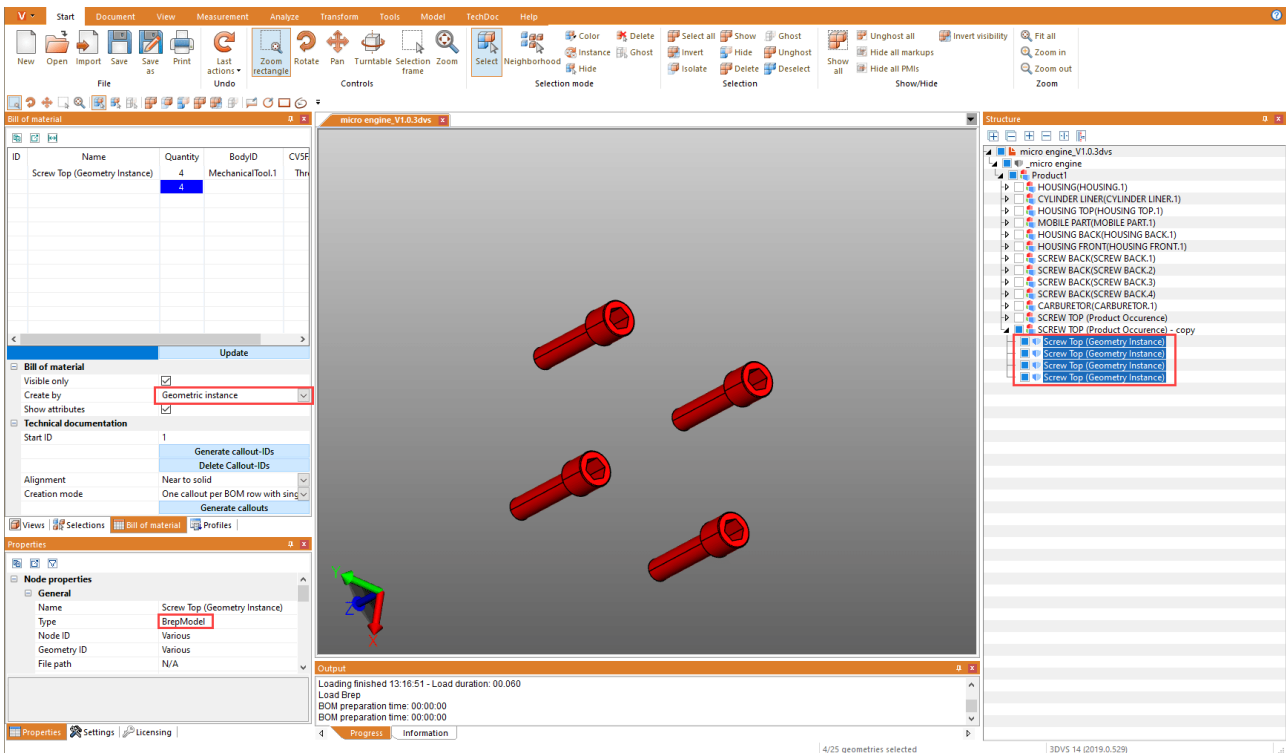

Product occurrence

This bill of material contains the number of lowest product occurrences in the structure (type **PRODUCTOCCURENCE**).

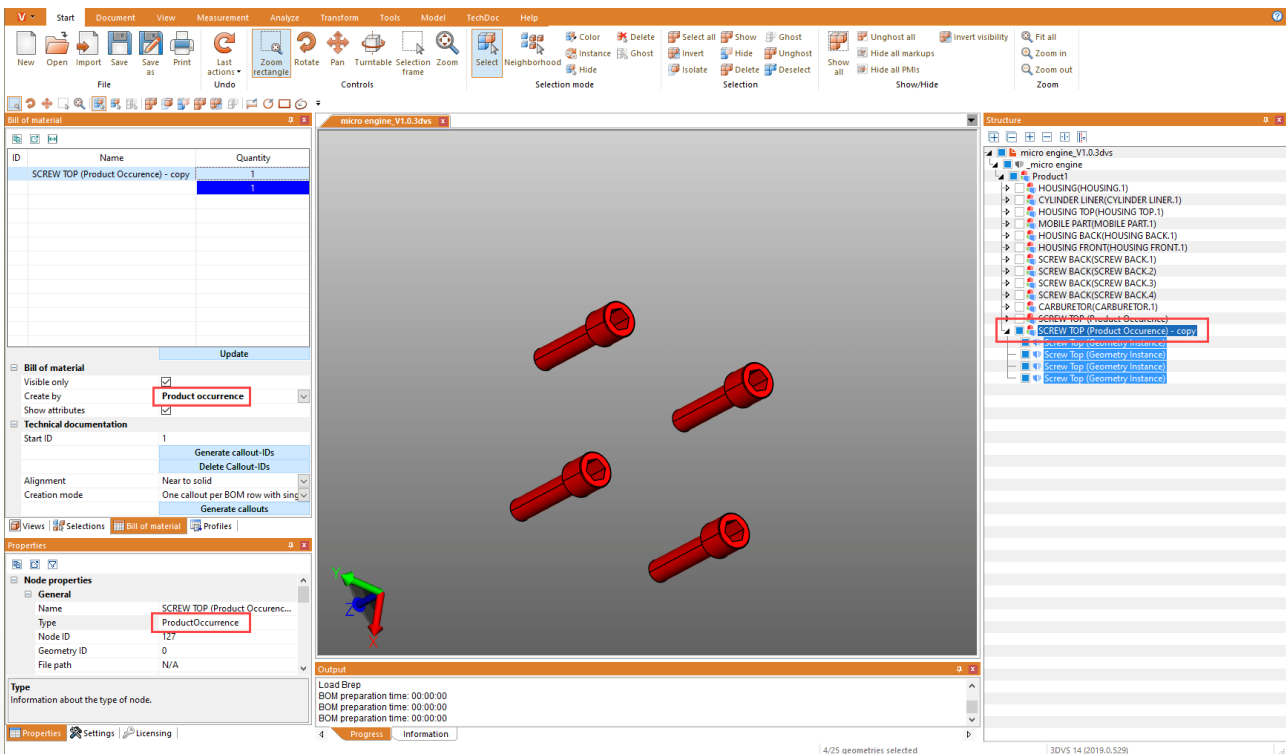

Selection

This bill of material contains the number of the highest structure level of a selection. This allows you to create a bill of material on any hierarchy levels for more complex models.

Note : A selection at a specific structure level can easily be created for the entire model. To do this, select the desired structure level and then press the last button under the title bar of the structure window (☐) to select all nodes of the same level.

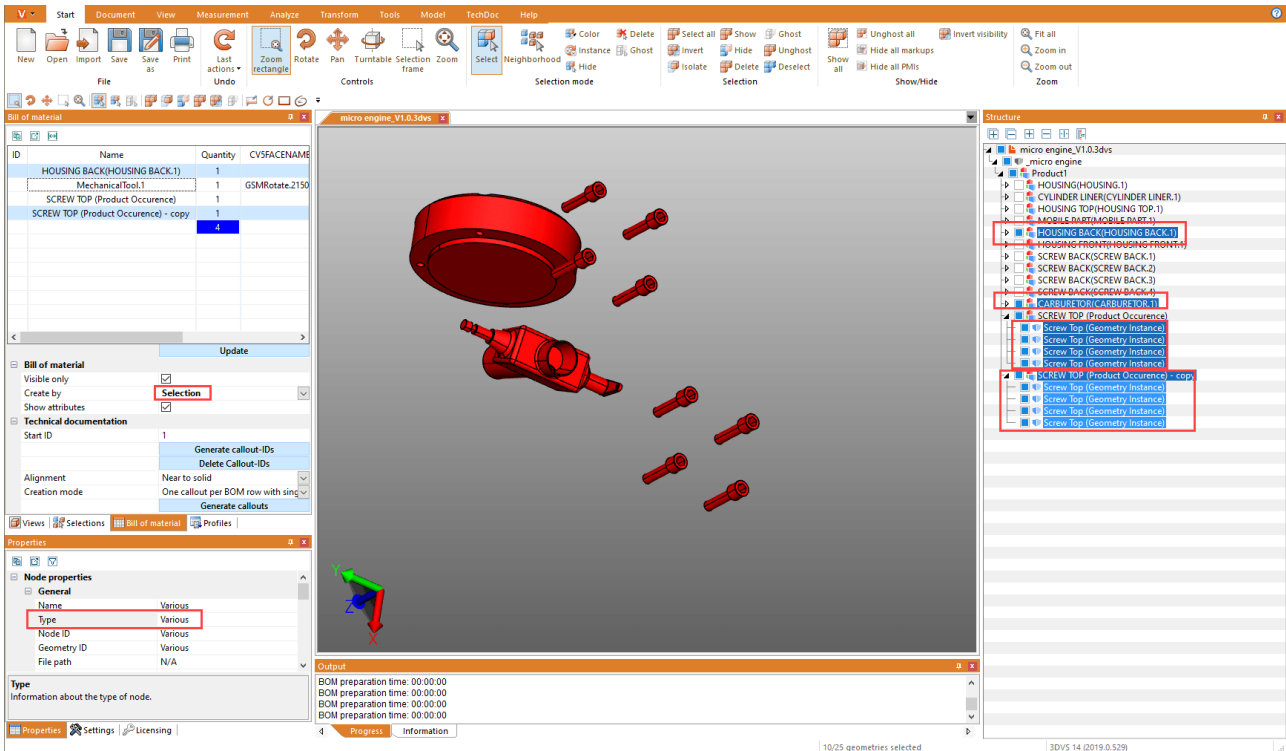

2.26.2 Callouts

A callout is a textual markup element that is connected to a part of your model by a line, an arrow or a similar graphic. Based on a previously created BOM [74], callouts can be generated and positioned automatically. You can do this using the functions in the **TECHNICAL DOCUMENTATION** category of the **BOM** tool pane.

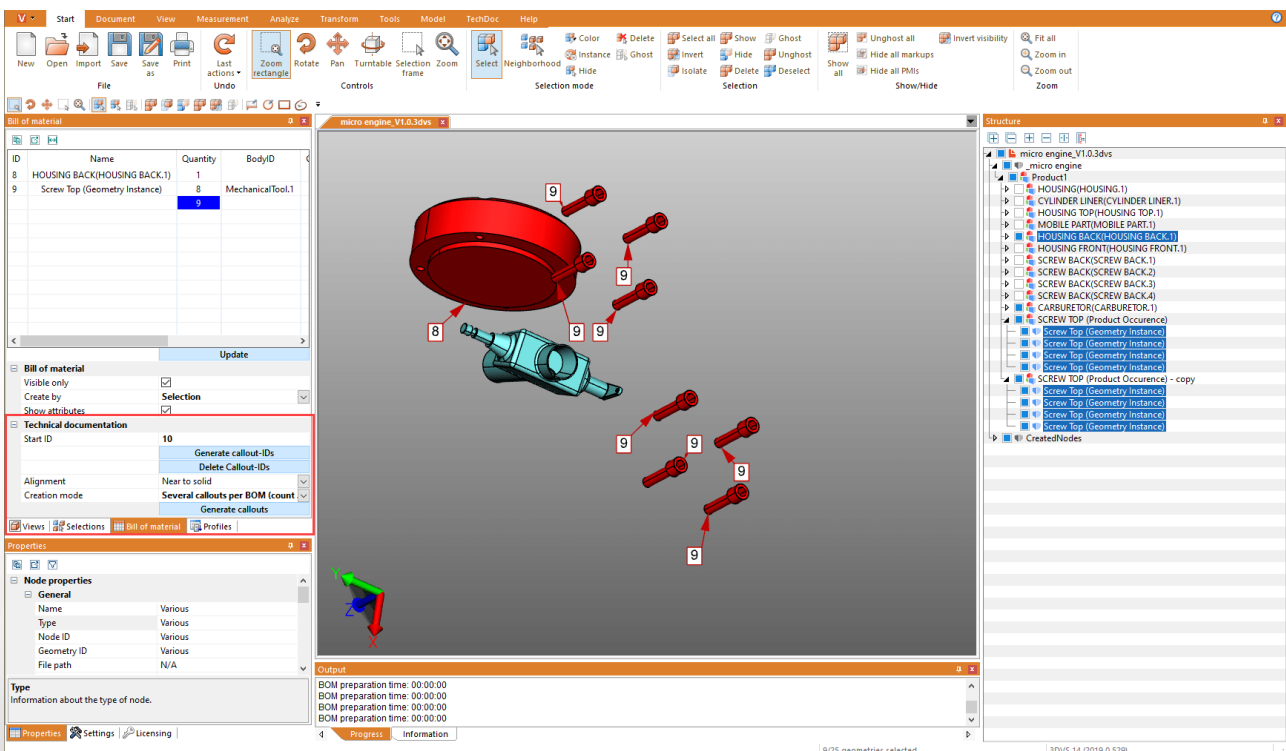

The process for generating callouts always consists of the following actions:

1. Creating a bill of material (see the chapter [BOM](#) ⁷⁴)
2. Generate callout IDs for the individual elements of the BOM (see below)
3. Create the callouts in the model (see below)

Generate callout IDs

To display callouts in the model, IDs must first be generated for the BOM lines to identify the callouts. These can be automatically generated for the entire bill of material by clicking the **[GENERATE CALLOUT IDS]** button.

Clicking the **[DELETE CALLOUT IDS]** button these are removed again. You can also enter, change, and remove individual IDs manually.

Note:

- When you update the BOM, all previously generated IDs are removed.
- The IDs begin with the value stored in the **START ID** field. This is incremented as soon as callout IDs have been created. This means that no duplicate IDs are generated for new bills of material. You can manually set the Start ID to a desired value.

Generating Callouts

If callout IDs have been generated as described above, you can now automatically add callouts to the model. Click on the **[GENERATE CALLOUTS]** button.

There are two settings available for generating callouts: alignment and creation mode.

The **ALIGNMENT** setting determines whether the callouts should be displayed, for example, in a rectangle around the entire model or only at the top.

The **CREATE MODE** setting allows you to specify whether a callout is to be created for each geometry or, as in the example, a callout with one connection per screw, etc.

Editing Callouts (Description of Menu Options)

Using the **TECHDOC** tab, you can create further callouts, edit existing ones and delete them. These functions are available to you in detail:

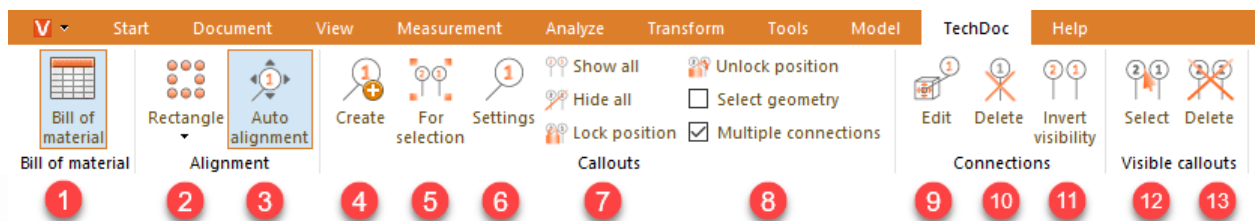

"BOM" section

Element	Description
1 BILL OF MATERIAL	Use this function to open or close the BOM window.

"Alignment" section

Element	Description
2 RECTANGLE	You can use this function to select how callouts already created should be aligned (e.g. as a circle or rectangle around the model, top and/or bottom, left and/or right of the

Element	Description
	model, etc.)
3 AUTO ALIGNMENT	When you realign the camera, created callouts are automatically adjusted to the new perspective. If you disable this option, the callouts remain in their position.

"Callouts" section

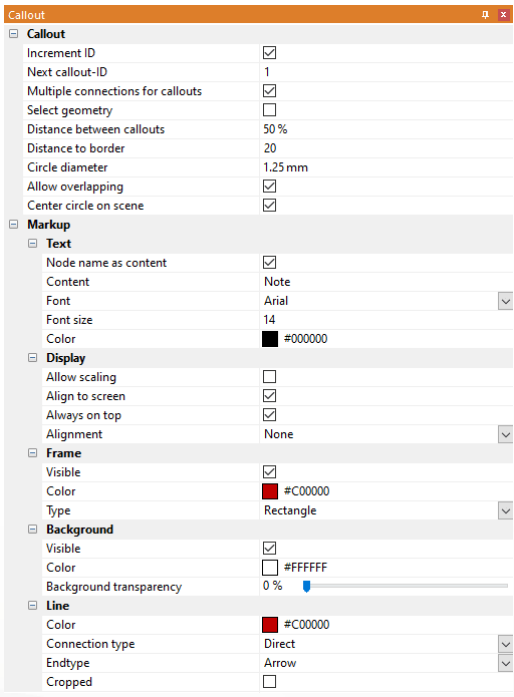
Element	Description
4 CREATE	<p>You can use this tool to create individual callouts to a geometry.</p> <p>Note:</p> <ul style="list-style-type: none"> ▪ If you click on a geometry without a callout, a callout with ID 1 is created or incremented by 1. ▪ You can read and set the counter for the next ID in the callout settings (see 6).
5 FOR SELECTION	<p>Use this tool to create callouts for all geometries of a selection.</p> <p>Note:</p> <ul style="list-style-type: none"> ▪ A callout is generated for each selection. ▪ If the MULTIPLE CONNECTIONS function is activated (see 8), a callout with one connection per geometry is generated.
6 SETTINGS	<p>Use this button to open the settings window for callouts. Here you can define settings for the behavior and visualization of callouts.</p> 
7 SHOW ALL	This function displays all hidden callouts. The visibility of markups and PMIs is not changed.
HIDE ALL	This function hides all visible callouts. The visibility of markups and PMIs is not changed.

	Element	Description
	LOCK POSITION	This function fixes the callout position for manual and automatic alignment. All visible or selected callouts are locked. This property can be found in the Properties window under the CONSTRAINTS category as soon as a callout has been selected.
8	UNLOCK POSITION	This function allows the manual and automatic alignment of callouts again. All visible or selected callouts are unlocked. This property can be found in the Properties window under the CONSTRAINTS category as soon as a callout has been selected.
	SELECT GEOMETRY	You can activate this check box to select the referenced geometry/geometries when selecting a callout. Accordingly, when selecting a geometry, the callout and all other geometries referenced by this callout are selected.
	MULTIPLE CONNECTIONS	If you select several geometries and create callouts for this selection (see FOR SELECTION function (5)), you can specify whether a callout should be created for each geometry or a callout with connections to all selected geometries.

"Connections" section

	Element	Description
9	EDIT	If you have already created callouts, for example, using the bill of material (BOM), you can use this function to subsequently edit their connections. For this, activate this function first. You then have the following options: <ul style="list-style-type: none"> You can click on a geometry already referenced by a callout to reposition its connection. The callout is also selected hereby! You can select a callout and then click on a geometry to change the position of an existing connection or create an (additional) connection.
10	DELETE	You can use this function to delete existing callouts. For this, activate this function first. <ul style="list-style-type: none"> If you click on a callout or its connection, this callout is deleted. If you click on a referenced geometry of a callout, the connection is deleted. The callout is also deleted with the last connection.
11	INVERT VISIBILITY	You can use this function to invert the visibility of the callout. For this, activate this function first. <ul style="list-style-type: none"> If you click on a callout or its connection, all connections are shown or hidden. If you click on a referenced geometry of a callout, only this connection is shown or hidden.

"Visible Callouts" section

	Element	Description
12	SELECT	You can use this function to select all visible callouts.
13	DELETE	You can use this function to delete all visible callouts.

Note : Individual callouts can be edited as usual using the structure or the selection mode in the **START** tab.

2.27 Generate, Copy and Move Nodes

Clicking the **CREATE** button in the **MODEL** tab will create a new structure node in the model structure. This new **NODE** is appended to the top node and is the lowest one in the list.

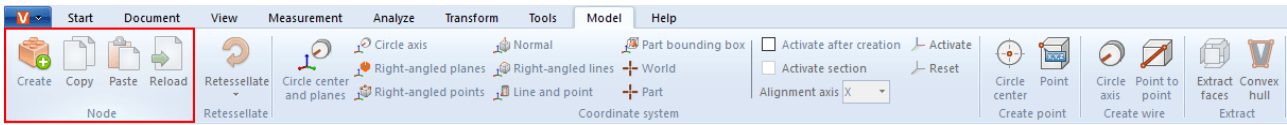

The buttons **COPY** and **INSERT** allow nodes (and any geometries below them) to be copied from the structure to be inserted at another location. These functions are accessible via the context menu when right clicking the structure. Copied nodes are identified by the suffix "- copy".

Alternatively, you can click a node and move it onto another node, which will then be appended in the last position below the target node.

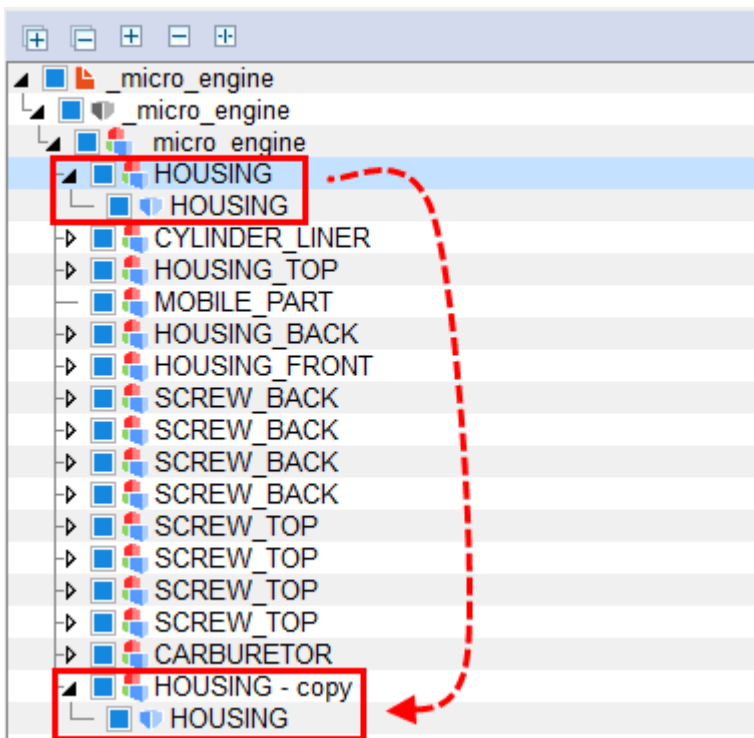

2.28 Reload Nodes

The button **RELOAD** is used in connection with the import setting **READ STRUCTURE ONLY**. This function is used for large assemblies with long load times. With creation enabled, only the model structure is loaded and visualized in the model structure. Individual parts can only be reloaded separately via their relevant node.

Select the desired node(s) (see chapters [Object Selection](#)^[23] and [Saving Selections](#)^[24]) and click the **RELOAD** button or use the context menu by right clicking on your selection.

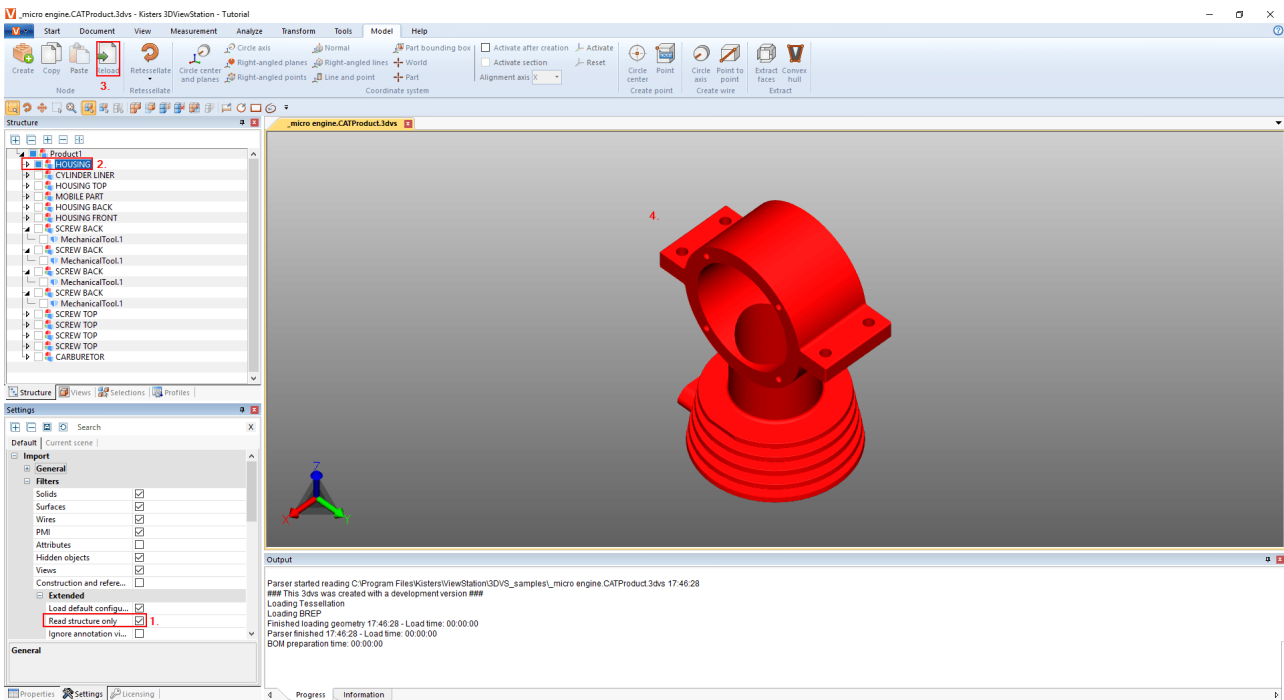

2.29 Node Retessellation

The button **RETESSELLATE** offers you the possibility to change the quality of the tessellation afterwards, provided that geometry data (BREP) are part of the model (see chapter [Opening a CAD file - Import settings](#) [15] and [View and Edit Properties of Selected Objects](#) [25]).

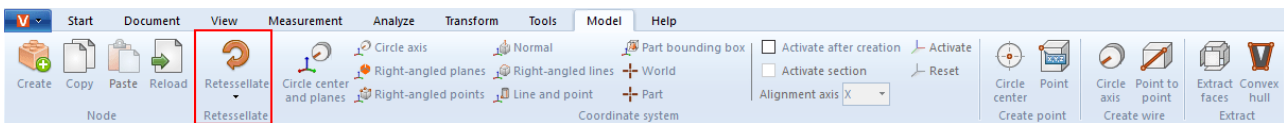

- Select the node(s) in the structure or the relevant geometries in the model area to adjust the tessellation quality.
- As a next step, click the **RETESSELLATE** button in the **MODEL** tab and specify the desired tessellation quality. Alternatively, you can right click your selection in the structure or the selected geometries to retessellate via the context menu item.
- Specify the custom quality setting in **SETTINGS** under **IMPORT SETTINGS**. For more information, see the [info box](#) [8].

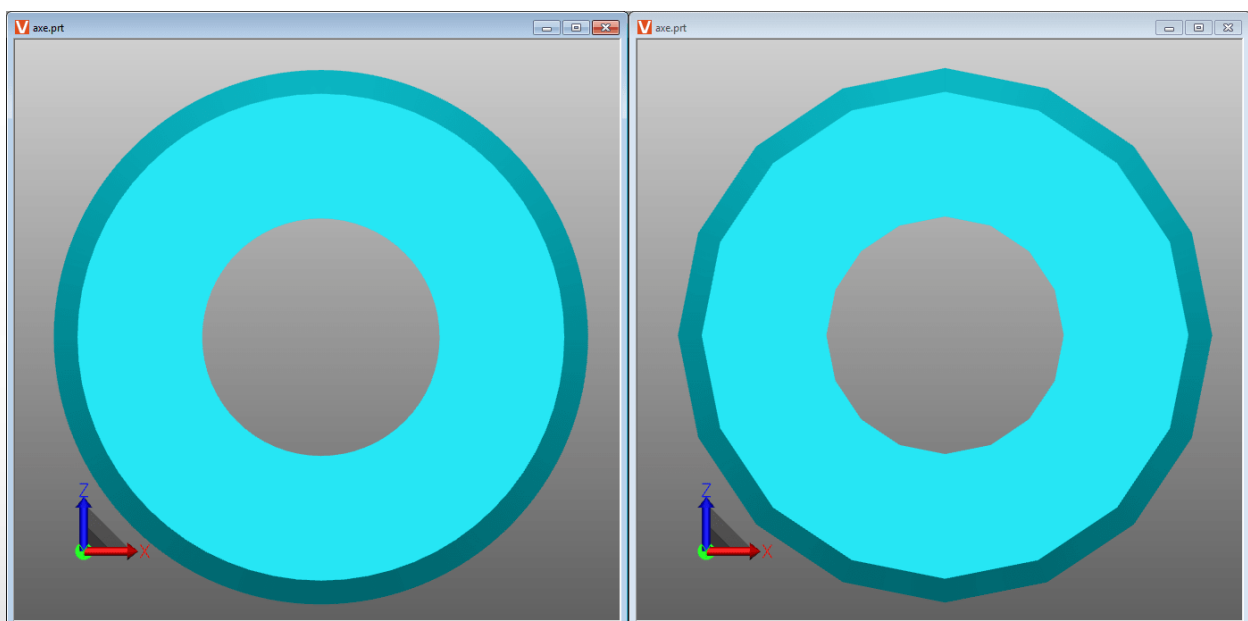

Difference between a very high (left) and very low (right) tessellation quality.

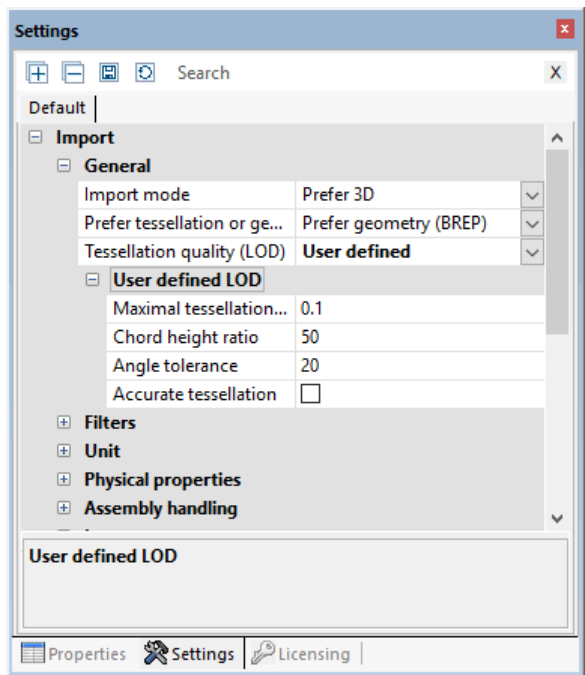

2.30 Generate Coordinate System

3DViewStation allows you to generate and activate custom coordinate systems to use as reference for various functions (e.g. for [Transformation](#) .

You can use various methods for the generation of coordinate systems. Each option displays a preview of the coordinate system:

CIRCLE CENTER AND PLANES: Select a circle into the center of which you want to place the coordinate origin. Next, click to select at least 2 planes perpendicular to each other. A preview of the coordinate system is displayed. Click the background to complete the creation. You didn't select enough planes if no preview is shown when you position the cursor on the background.

CIRCLE AXIS: As a first step, select the desired circle and specify the alignment of the remaining axes with another click.

RIGHT-ANGLED PLANES: Select 3 planes perpendicular to each other. Clicking a previously selected plane again will invert the current axis.

RIGHT-ANGLED POINTS: The first point denotes the origin, the second point the x axis and the third point the y and z axis. Lines and edges are captured to generate e.g. a coordinate system on the corners of rectangular solids.

NORMAL: Generates a coordinate system vertically on a plane.

RIGHT-ANGLED LINES: With a method similar to Right-angled points, you can generate a coordinate system by selecting 2 consecutive lines at right angles to each other.

BY LINE AND POINT: In a first step, select a line specifying the z axis. You can then specify the remaining axes with another click (point).

PART BOUNDING BOX: Generates a coordinate system at the center point of the part bounding box of a geometry. Activate the function first, and then select the part.

WORLD: Generates a coordinate system at the center point of the part bounding box of a world.

PART: Generates a coordinate system at the origin of the selected part.

ACTIVATION of a coordinate system: A generated coordinate system must be activated to allow its use as reference for e.g. measurements. To activate a coordinate system, it must first be selected in the model area or in the structure, followed by an activation via the button **ACTIVATE**. An active coordinate system is displayed in color. The position of the coordinate system visualization in the bottom left corner of the model area is adjusted in accordance with the active coordinate system.

Click **RESET** to revert to the original world coordinate system.

You can automate the activation of a created coordinate system as follows:

- In the **info area**, select the **SETTINGS** tab.
- Switch to the **ACTIVE SCENE** tab in the settings.
- Navigate to **COORDINATE SYSTEMS > ACTION** in the tree structure.
- Select the **ENABLE AFTER GENERATION** check box.

The sub option of this setting allows the generation of a cut in the specified alignment axis for this coordinate system.

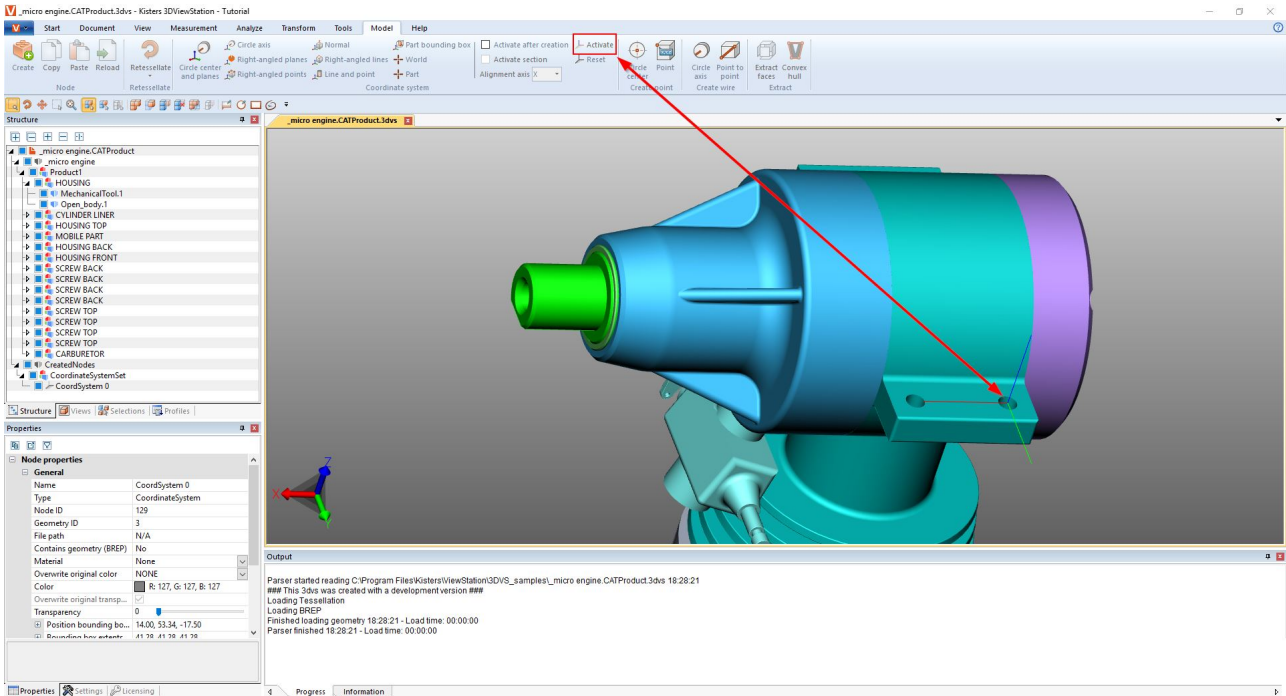

2.31 Generate Auxiliary Geometries

Auxiliary geometries like points, lines or areas are frequently needed for the analysis of parts. If these are not available, you can use the following auxiliary geometries to generate them.

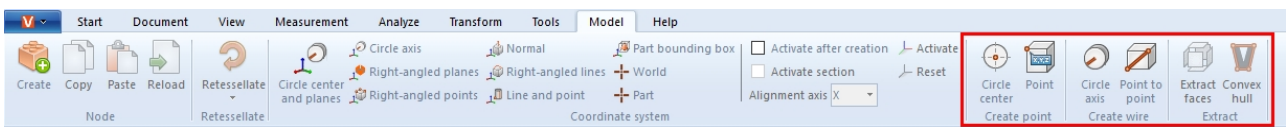

Function	Description
CIRCLE CENTER	Generates the circle center point via the selection of a circle segment (illustration on the left).
POINT	Generates a point at any selected location of a geometry.
INTERSECTION	Creates a point at the intersection of two lines.
CIRCLE AXIS	Generates a circle axis via a circle segment (illustration in the middle).
POINT TO POINT	Any two points of a geometry can be selected to generate a line between two points.
EXTRACT FACES	Generates a surface model from a solid model. Select the geometry and decompose it into surfaces via the function EXTRACT FACES (illustration on the right).
MERGE OBJECTS	Merges all selected objects into a single object and creates a new geometry node.

Function	Description
HIERARCHICAL MERGING	Merges all objects in a selected node.

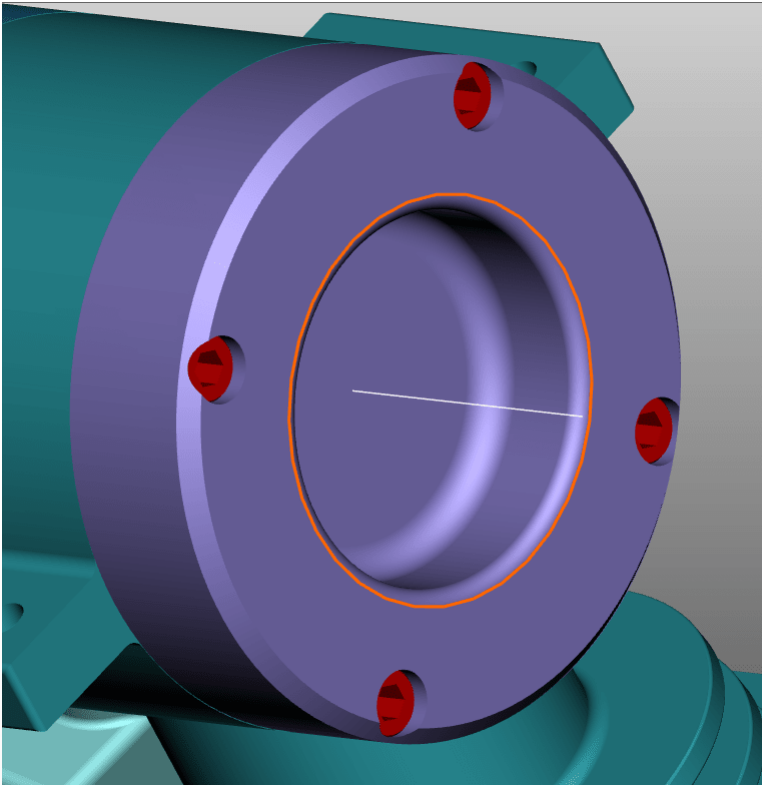
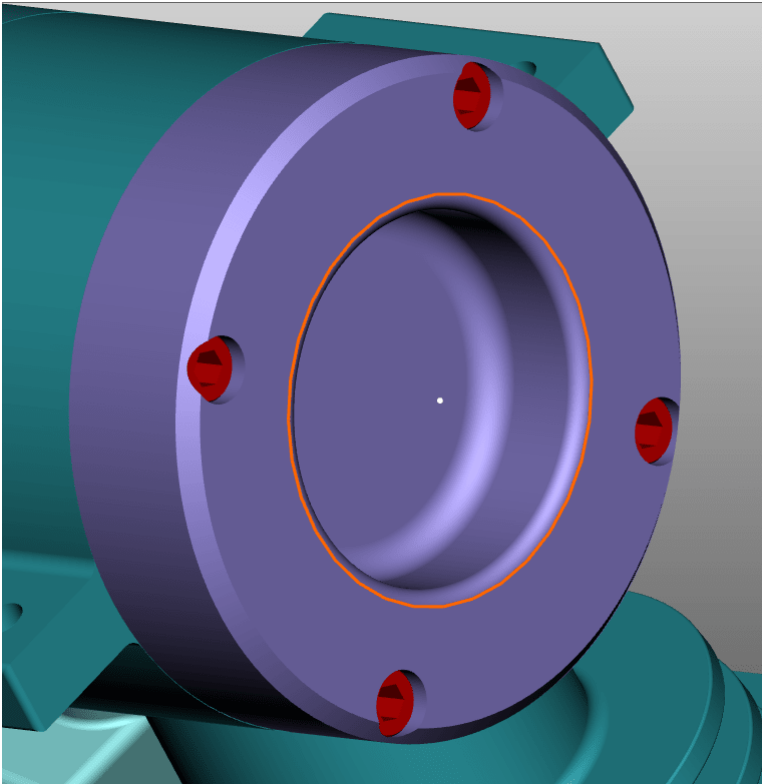

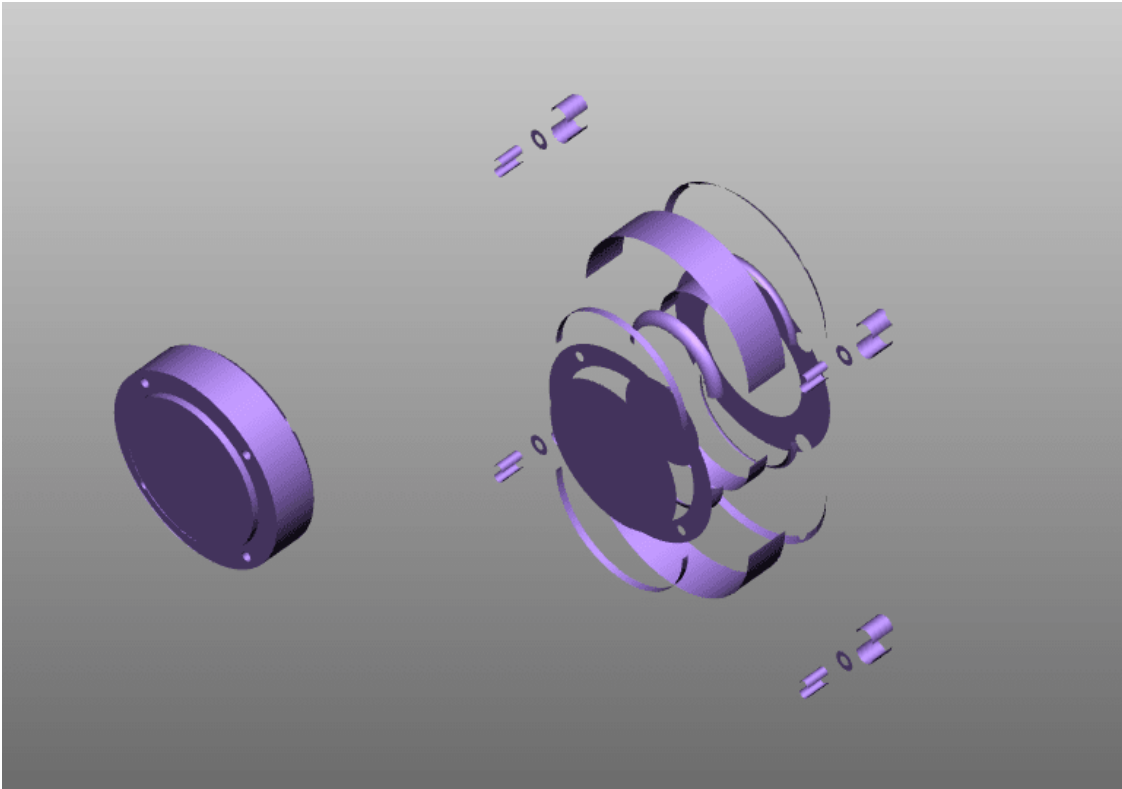

CONVEX HULL: Distorts a geometry by generating a hull. The original geometry is hidden.

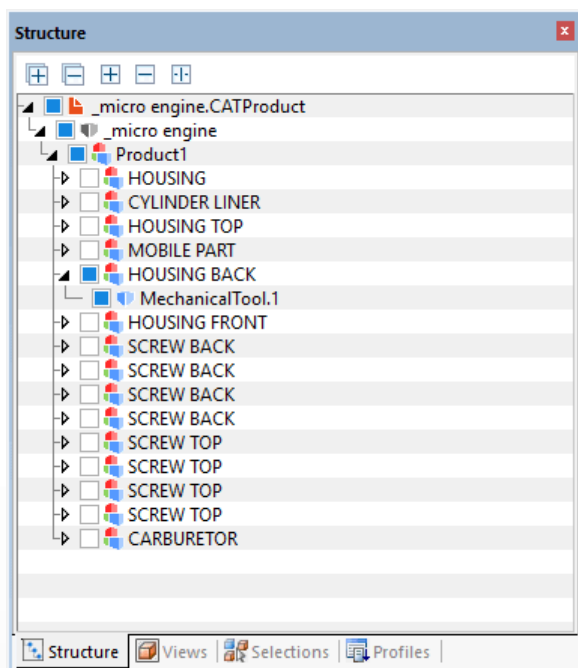

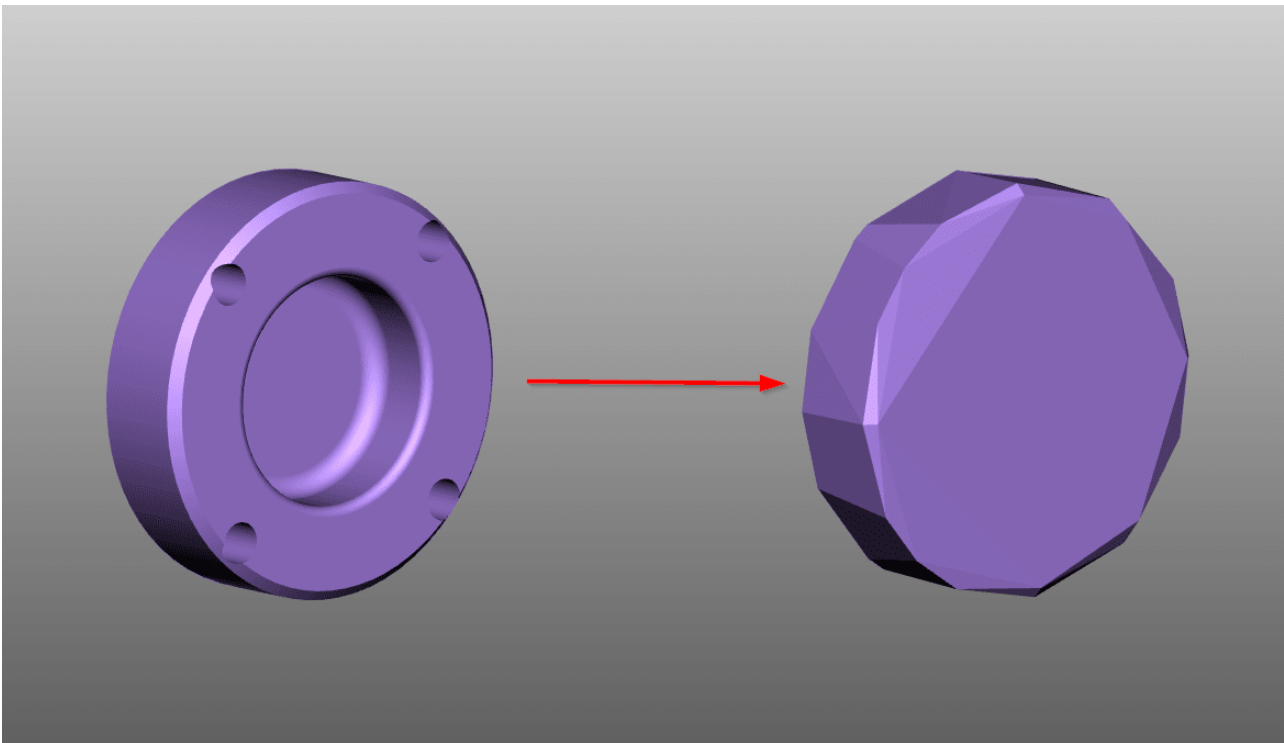

All auxiliary geometries created by 3DViewStation are saved in the structure below the node **CREATEDNODES**. One exception is geometries generated via the function **EXTRACT FACES**. These will be placed directly below the relevant product node with the suffix **FACES**.

2.32 Font substitution (2D)

When importing a drawing, 3DViewStation checks whether the fonts used in the drawing are available on the system. If fonts used are not available to the system, font substitution can be performed.

Note: These settings apply only to the drawing formats of CATIA, Creo/ProE, NX, SolidEdge and SolidWorks.

You can adjust the font substitution settings in the import settings.

- In the info area, select the **SETTINGS** tab. See [Settings](#) 
- Navigate in the tree view to: **IMPORT > FONTS > DRAWINGS**

The following options are available:

Rasterization of all fonts

If the **RASTERIZE ALL FONTS** option is enabled, all fonts will be rasterized. This means that font recognition and substitution is turned off and each character is displayed as a group of lines.

Rasterization disabled

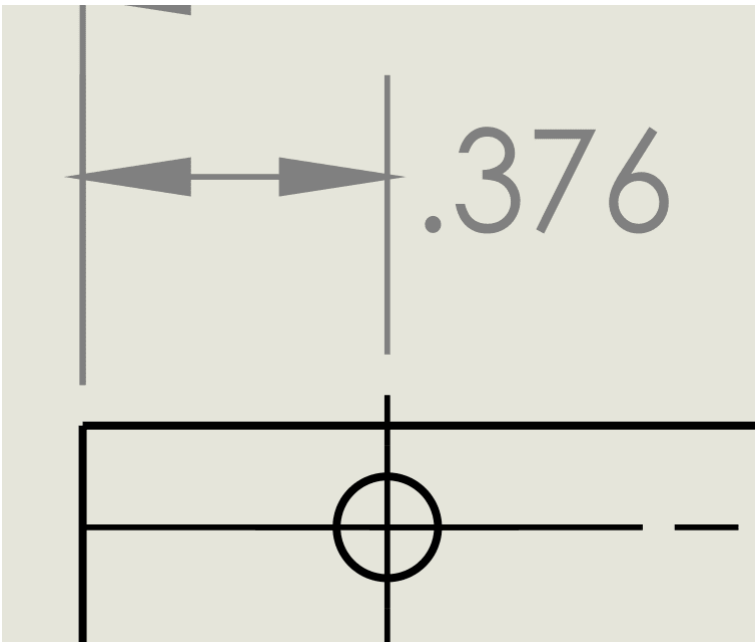

Rasterization enabled

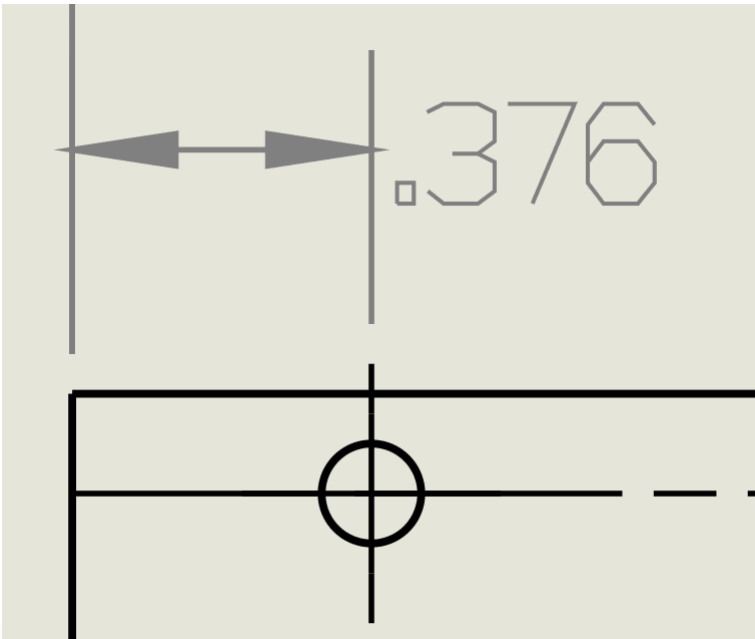

Default substitution font

The **DEFAULT SUBSTITUTION FONT** option allows you to specify the substitution font. The selected font is used whenever a font used in the drawing cannot be found on the system.

Show missing font dialog

If the option **SHOW MISSING FONT DIALOG** is activated, a dialog is displayed as soon as you import a drawing that contains fonts that are not available on the system.

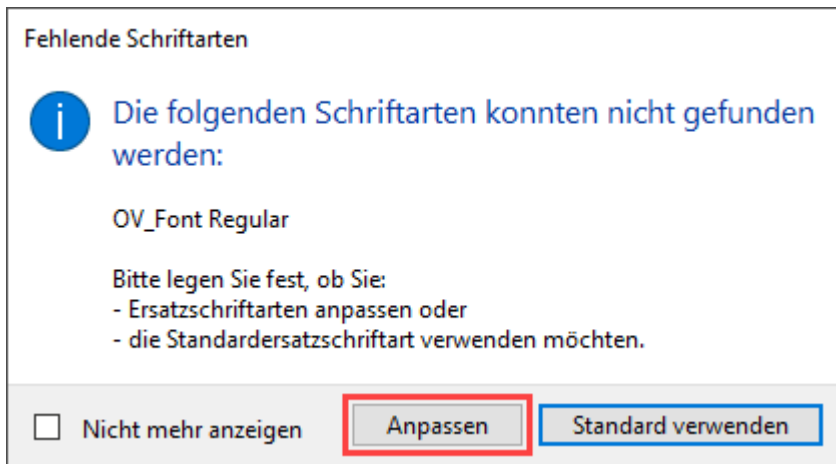

To define a replacement font for a font not found yourself, click **[CUSTOMIZE]**.

In the table (CSV format) that opens automatically, you can define which fonts should be used as replacement fonts.

- Remove the # character in front of the entry (font) you want to customize.
 - Enter the location of the replacement font in the second column.
 - Save the file to the original location.
- Note:**
- The file must be saved in CSV format.
 - 3DViewStation only supports fonts of the type TTF, TTC and selected OTF fonts when importing drawings.

The entered replacement fonts will always be used for these fonts in the future.

If you click the **[USE DEFAULT]** button in the **MISSING FONTS** dialog, the **default replacement font**  is used for fonts that do not exist.

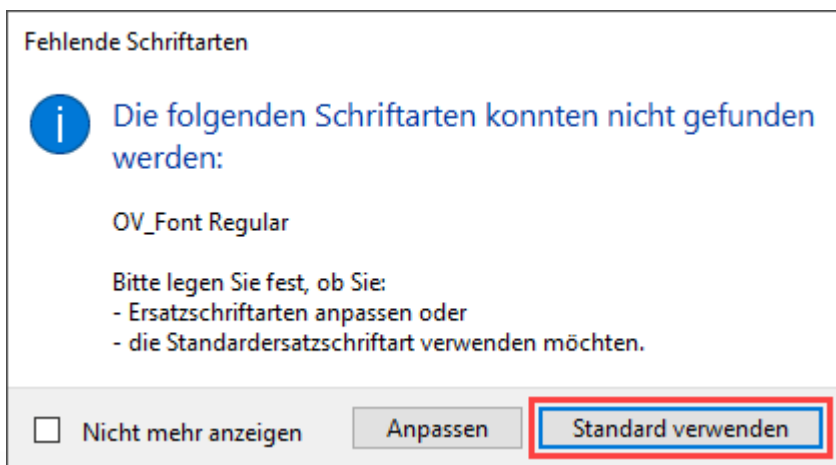

Note: This selection applies only to the current import operation. For each additional drawing with non-existent fonts, the dialog appears again.

If you activate the **DO NOT SHOW AGAIN** check box in the **MISSING FONTS** dialog, the option defined **here**  will automatically be used when importing drawings with unknown fonts in the future.

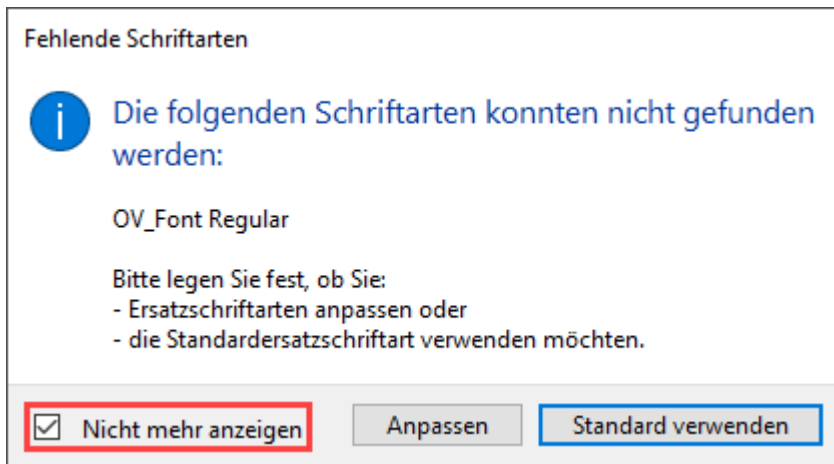

You can also undo this setting.

- In the info area, select the **SETTINGS** tab. See [Settings](#) ¹⁸
- Navigate in the tree view to: **IMPORT > FONTS > DRAWINGS**
- Uncheck the **SHOW MISSING FONT DIALOG** check box.

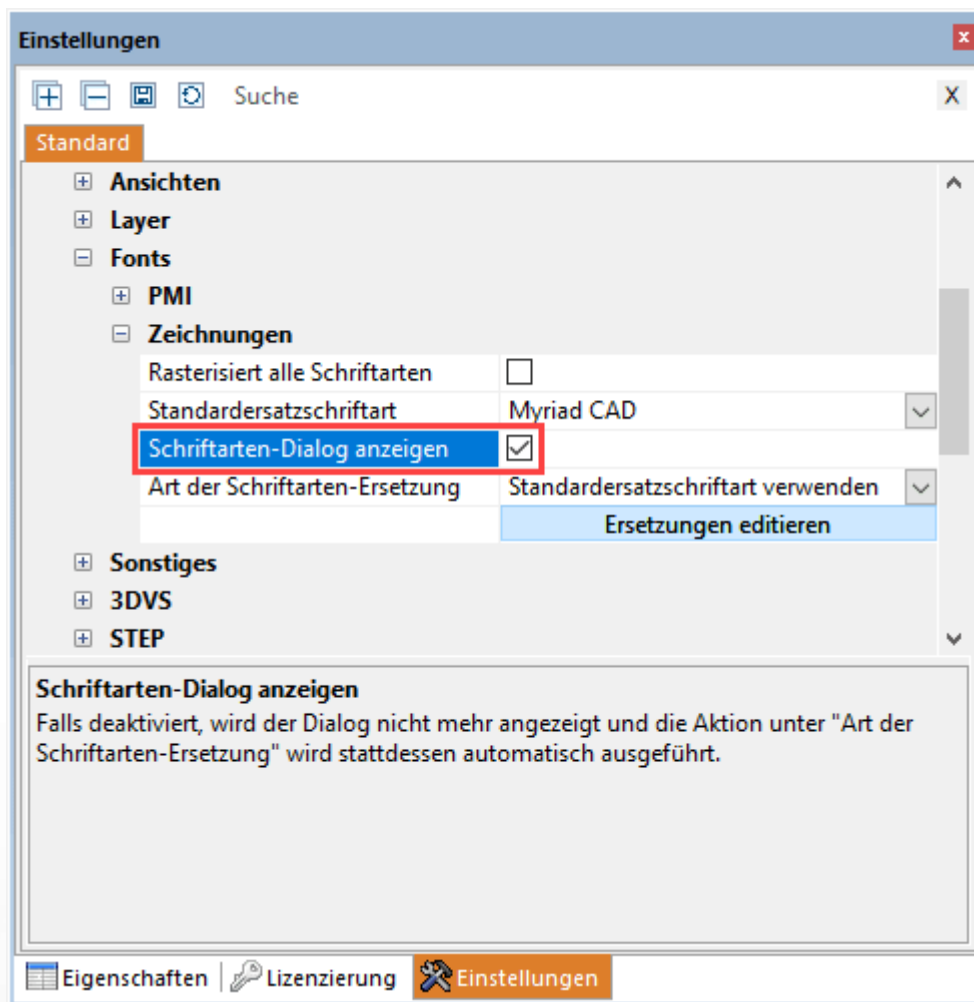

Type of font substitution

With this option you can permanently define how 3DViewStation should behave when importing drawings with unknown fonts.

Option	Description
CUSTOMIZE SUBSTITUTION FONTS	You have the option to customize the substitute font as described here ⁹³ .
USE DEFAULT SUBSTITUTION FONT	The font specified in the Default substitution font option will be used as the substitution font for all unknown fonts.

Note: This option is relevant only if the **SHOW MISSING FONT DIALOG** check box is disabled. See [previous paragraph](#) ⁹².

Customize the substitution fonts

If you want to call up the table of substitution fonts independently of loading a drawing, proceed as follows:

- In the info area, select the **SETTINGS** tab. See [Settings](#) ¹⁸.
- Navigate in the tree view to: **IMPORT > FONTS > DRAWINGS**
- Click on **[EDIT SUBSTITUTIONS]**.

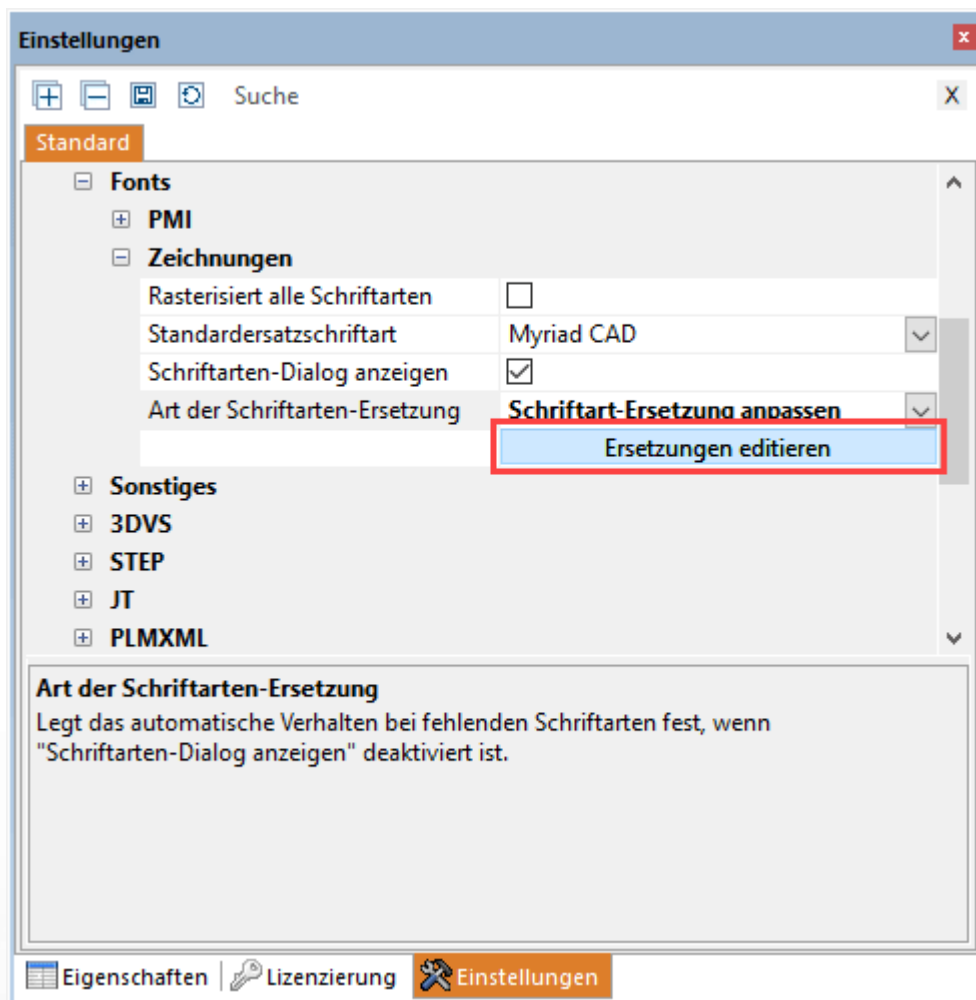

- Perform the customization steps as [described above](#) ⁹¹.

Alternative procedure

- Click on the tab **HELP**.
- Click on **USER**.
- In Windows Explorer (opens automatically), navigate to the folder

```
C:\Users\<<Username>\Documents\
```

```
Kisters\ViewStation\Resources\Fonts
```

- Open the `FontSubstitution.csv` file with spreadsheet software or a text editor.
- Perform the customization steps as [described above](#).

2.33 Attribute CSV import



This functionality is available **from version 2023.x**.

Structure of an attribute CSV file

Note: The CSV file must be saved UTF8 encoded. Other encodings, such as ANSI, may cause errors.

- The first line (1) of the CSV file represents the header.

```
# 3DVS Attribute CSV
```

Note: If this header line is not present, the file will be recognized as a normal CSV/TXT file.

- The second line (2) of the CSV file contains the attribute names (keys). The attribute names and the number of attributes can be freely assigned.
- The first column (3) contains the node name (or just a part of it). Each node can be assigned the keys defined in the second line.

	A	B	C	D	E	F	G	H	I	J
1	# 3DVS Attribute CSV									
2	Node name	SAP-ID	Sub-Revision	Class	Status	Editor	approved	Stock pcs		
3	1393342				released		yes	234		
4	1472686	4455667788				Albert Einstein	no			
5	1479757	4433221166	1	A	in work	Bob	no	9		
6	1528410_AF0	4488996644	1	A	in work	Steve	no	64		
7	1388836			C	released	Steve	yes	57		
8	8501505		7	C	in work	Steve	no			
9	8501503	33669966	5	D		Bob		8		
10	1493910_176657			D	in work	Bob	no	24		
11	1536684	11554433	5	E	released	Bob	no	46		
12	1397717_SOLID		2		released	Bill	no			
13	H10_7_8_14UNF		2	B	released		yes	51		
14	1399754			M	under review	Mick	no	34		
15	1526807_SOLID		8	M		Mick	no	10		
16	1388959SOLID		5	X	under review	Albert	no	20		
17	1397718		3	A	released	Albert		45		

Example:

```
# 3DVS Attribute CSV
Node name;SAP-ID;Sub-Revision;Class;Status;Editor;approved;Stock
pcs
1393342;;;released;;yes;234
1472686;4455667788;;;Albert Einstein;no;
1479757;4433221166;1;A;in work;Bob;no;9
1528410_AF0;4488996644;1;A;in work;Steve;no;64
1388836;;;C;released;Steve;yes;57
8501505;;;7;C;in work;Steve;no;
8501503;33669966;5;D;;Bob;;8
```

```
1493910_176657;;;D;in work;Bob;no;24
1536684;11554433;5;E;released;Bob;no;46
1397717_SOLID;;;2;;;released;Bill;no;
H10_7_8_14UNF;;;2;B;released;;;yes;51
1399754;;;M;under review;Mick;no;34
1526807_SOLID;;;8;M;;;Mick;no;10
1388959_SOLID;;;5;X;under review;Albert;no;20
1397718;;;3;A;released;Albert;;;45
```

Import

You can import the attribute CSV file by dragging and dropping the CSV file onto the 3D model.

Alternatively, in the **START > IMPORT** tab, activate the drop-down menu and select **ATTRIBUTE CSV IMPORT**.

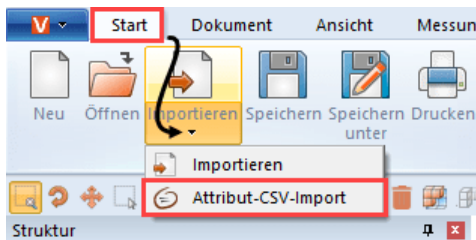

When you import an attribute CSV file into a 3D model, all nodes found are assigned the defined key-value pairs as attributes.



Chapter III:

Export and Print

3 Export and Print

3DViewStation offers options for format conversion, saving of edited 3D models, as well as a 2D export and print function.

- Save, Save as (Export) ^[97]
- 2D Export (Screenshot) ^[97]
- Export Settings ^[98]
- 3D-PDF Export with templates ^[99]
- Print ^[104]

3.1 Save, Save as (Export)

SAVE AS in the tab **START** allows you to export the loaded model in a variety of formats. The export of geometry data (BREP) in 3D neutral formats requires the use of the **PREFER GEOMETRY (BREP)** mode when loading the model (see chapter [Opening a CAD File - Import Settings](#) ^[15]). The import preferences **FULL** and **DETAILED** of the import dialog support this mode.

Use the KISTERS 3DViewStation format (.3dvs) to save all annotations, views and other adjustments. This format was specifically optimized for short load times and small file sizes. Compare the load time of a native CAD file with that of a 3DViewStation file. Load times and file sizes can be further optimized; see chapter [Opening a CAD File - Import Settings](#) ^[15].

Take note of the [Export settings](#) ^[98] for the relevant format before saving.

Using the **SAVE** function, only the 3DVS format is available. The advantage of this option is that you only need to specify a location when saving for the first time. During further editing, a click on **SAVE** is sufficient to save the work. The previously saved 3DVS file is overwritten without any confirmation query. If the work is to be saved in another 3DVS file, please use the **SAVE AS** function.

3.2 2D Export (Screenshot)

Save as

You can save the current view of the model space as a 2D image ("screenshot").

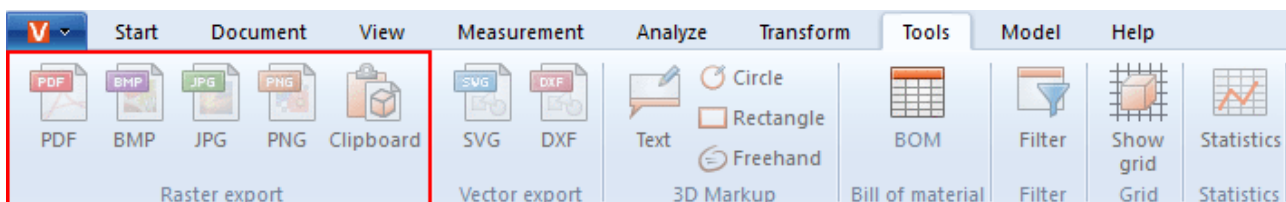

- Click on the **TOOLS** tab.
- Click on the **FILE** button in the **EXPORT / SCREENSHOT** area.
- In the **SAVE AS** dialog, select the desired file name and file type to save. You can select the following file types to save the view:
 - **Raster formats:**
 - PDF, BMP, JPG, PNG
 - **Vector-based formats:**
 - SVG, DXF, CGM
- Finally, click on the **[SAVE]** button.

Copy to Clipboard

You can copy the current view of the model space to the clipboard.

- Click on the **TOOLS** tab.
- Click the **CLIPBOARD** button in the **EXPORT / SCREENSHOT** area.

The current view of the model space is now in the clipboard as a bitmap graphic and can be pasted into other applications.

3.3 Export Settings

Export parameters can be configured in the sub pane **SETTINGS > DEFAULT** in the **EXPORT** area.

If the **SETTINGS** pane is not visible to you, you can display it again via **VIEW > SHOW PANES > SETTINGS**.

Please note that the geometry (BREP) can only be exported if geometry data (BREP) were included in the import (see chapter [Opening a CAD File - Import Settings](#) ^[15]).

You can specify which information should be exported for all formats via **EXPORT > 3D > GENERAL**, provided the target format supports that information. You can speed up the export by setting the write mode to **WRITE TESSELLATION ONLY** under **EXPORT > 3D > GENERAL** if you only wish to write tessellation.

Some of these options and other format-specific settings can be found in the respective categories of the supported formats. By selecting a settings entry you get detailed descriptions in the lower area of the window – in the so-called [Help Box](#) ^[8].

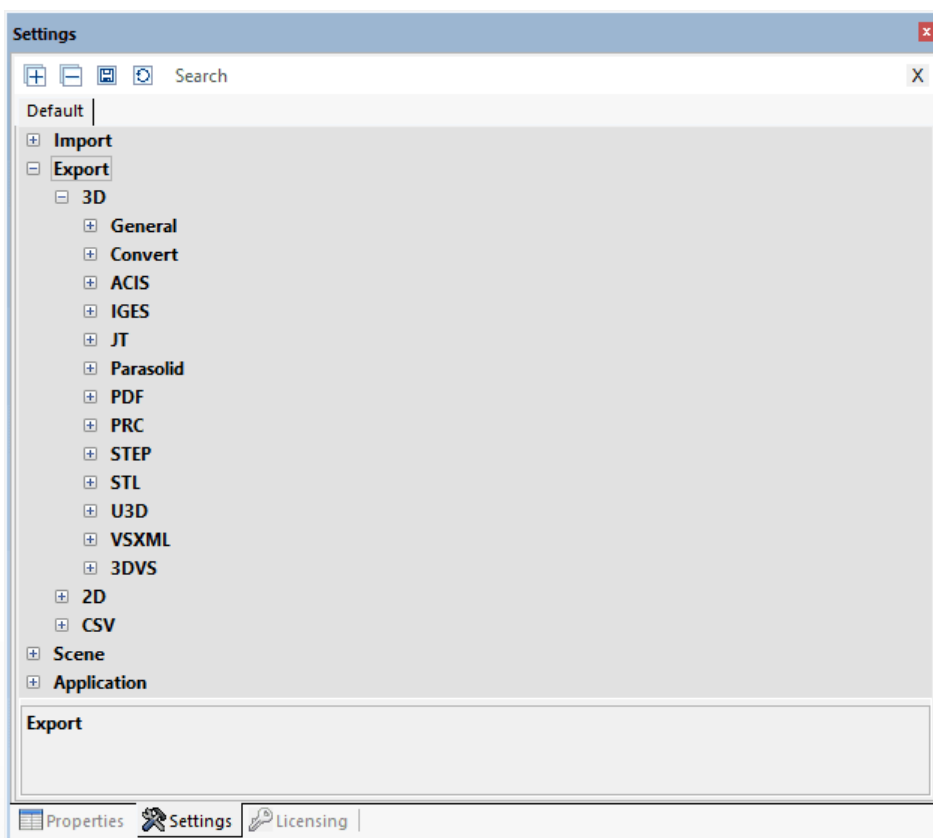

3.4 3D-PDF Export with templates

With 3DViewStation you can export your model as 3D-PDF and optionally embed 2D templates. 2D templates can be displayed directly without having to load the much more complex 3D model information. Thus, the template can be used to quickly retrieve important information. If required, you can switch to the 3D model view by double-clicking on the template. Some KISTERS demo templates are available for this purpose, which can be adapted to your needs. This chapter explains how to use and customize PDF templates or create your own ones.

The 3D PDF export can be found in the **START > FILE > SAVE AS** tab. The settings to be used, for example to select a template, can be found in **SETTINGS > DEFAULT > EXPORT > PDF**.

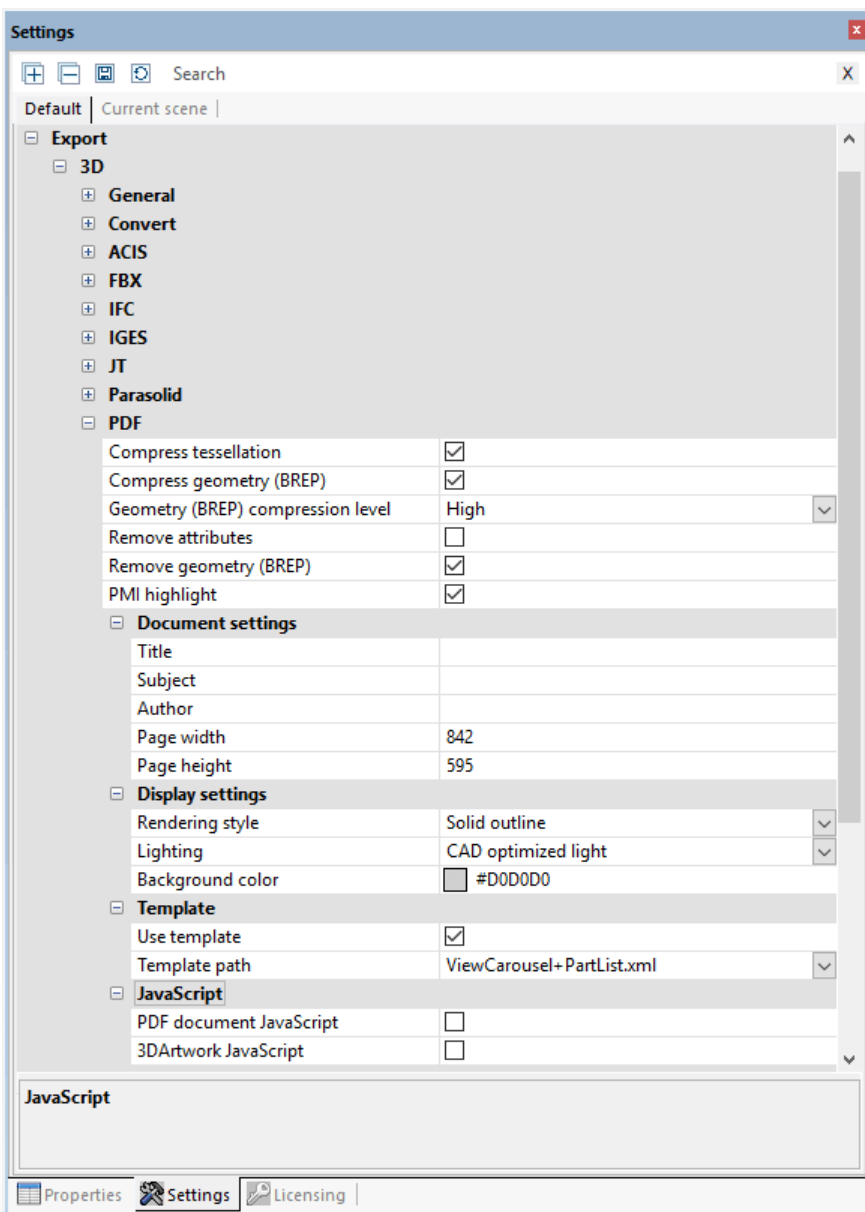

If the **SETTINGS** pane is not visible to you, you can display it again via **VIEW > SHOW PANES > SETTINGS**.

To use 3D PDF templates, activate the **USE TEMPLATE** check box under **DEFAULT > EXPORT > 3D > PDF > TEMPLATE**.

You can then select one of the KISTERS demo templates. These templates demonstrate some of the possibilities offered by templates. For example, the template `ViewCarousel+PartList+Logo.xml` shows a parts list, the views (if available) as a view carousel in the lower template area and the KISTERS logo. `ViewCarousel+PartList+ActionButton.xml` simple integration of JavaScript into a template.

Customizing and creating 3D templates

A template consists of at least two components:

- The Adobe form (*.pdf): The layout is defined here, e.g. where the field for the date should be, as well as various design elements.
- The XML description (*.xml): This file defines the relationship between the content, e.g. the current date, and the field in the form.
- Further components such as images (logos) and JavaScript are possible.

A template can be created in three steps:

1. First a design with all static elements like background color, lines, fixed texts etc. is created and exported as PDF.
2. The PDF created is then converted with Adobe Acrobat Pro into a form that contains the fields to be filled.
3. Finally, the referencing of contents to the fields of the form is created via an XML file.

1. Creating a design

Create your desired design with static elements such as background color, frames, fixed texts, etc. and export the finished design as PDF. This can be implemented with Microsoft PowerPoint or Word, for example. The file name corresponds to the template name later displayed in the KISTERS 3DViewStation.

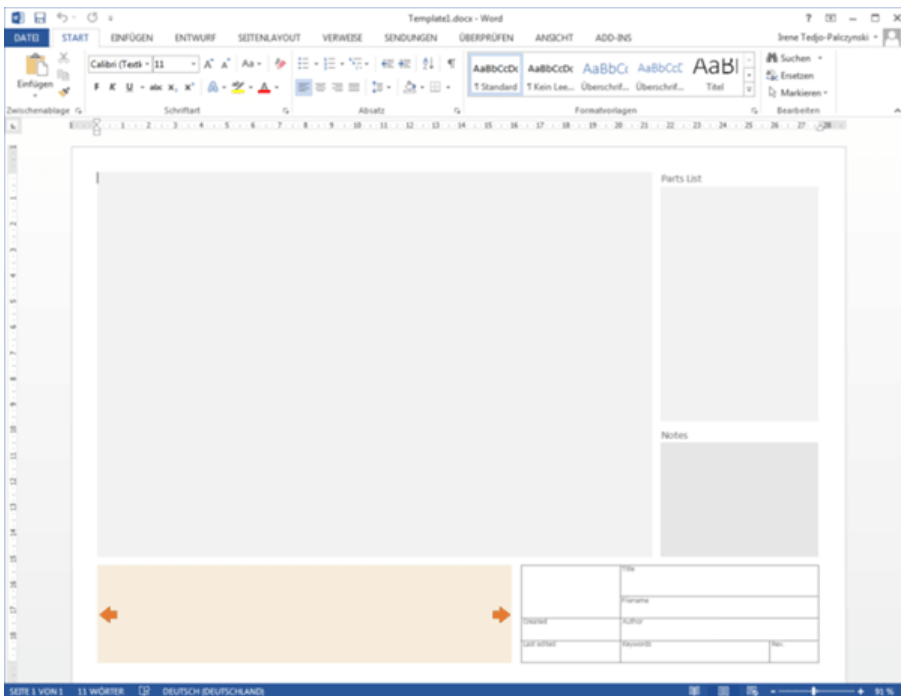

2. Creating a form with Adobe Acrobat Pro

- Open the previously created PDF file with Adobe Acrobat Pro, select the **PREPARE FORM** option on the **TOOLS** tab, and click **START** on the displayed page.
- Adobe Acrobat Pro now tries to detect fields automatically, e.g. text fields and tables with frames are detected. On this basis, recognized fields can now be edited and any various fields can be added. Corresponding field types should be selected for the various information that is transferred to the fields when exporting from the KISTERS 3DViewStation, such as a preview of the model, views, date, etc. Often, different field types are available for an information. Which one to use depends on the desired behavior. For more information about the required fields, see the [Available Design Elements](#) section below. To check the type of a field, open the properties by right-clicking on a field. You can read the type from the title bar of the properties.
You can find further information about creating forms with Adobe Acrobat Pro on the manufacturer's website.
- The name of a field is used to assign content. Therefore, it makes sense to choose unique names that correspond to the type of content. We recommend to not use special characters, umlauts and spaces.
- Once all fields have been defined, please save your changes.

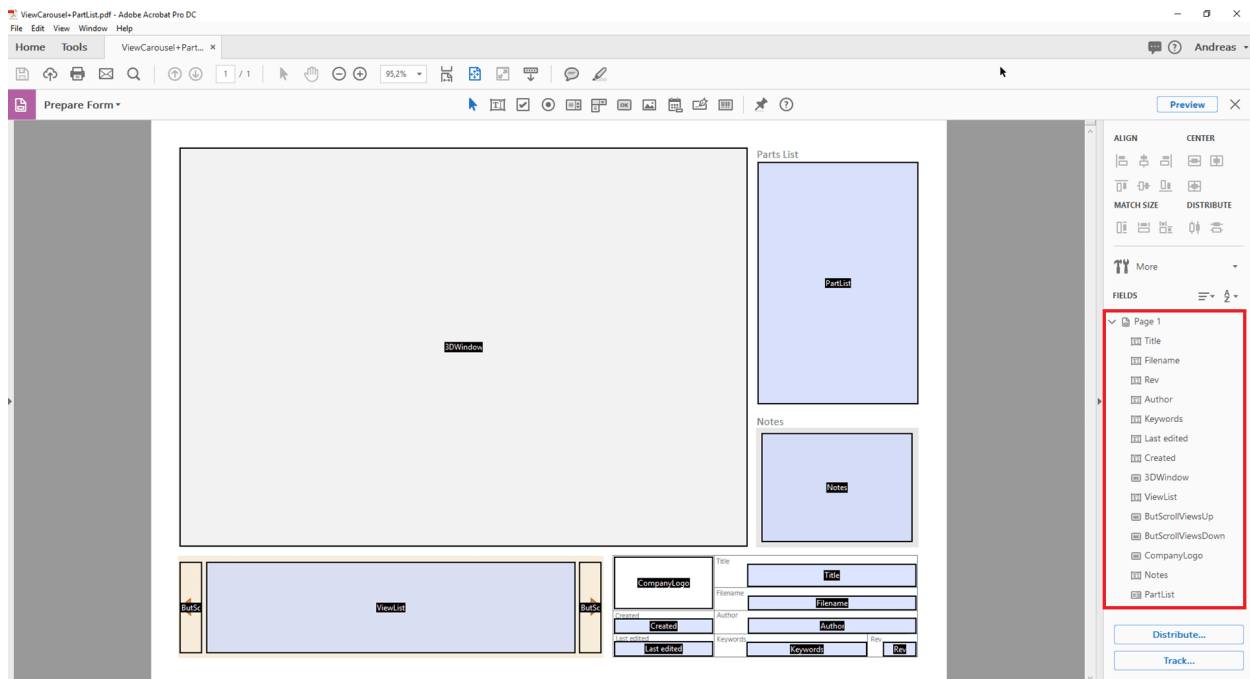

3. Referencing of fields with content using XML description

An XML description is used to display hierarchically structured data in the format of a text file. An editor can be used for editing, Notepad++ offers useful convenience functions.

Create a text file, e.g. by right-clicking on your desktop, in the context menu that appears select **NEW** and **TEXT DOCUMENT**. The file name should correspond to the name of the previously created PDF file. Replace the `txt` file extension by `xml`.

You have created two files so far: `TemplateName.pdf` and `TemplateName.xml`.

For further editing of the XML file you can use one of our examples for comparison. These can be found in the `installation directory > Resources > Templates > PDF`.

Each XML element has an opening and a closing tag (recognizable by the `/`). Tags can contain additional parameters. Between the opening and closing entry there can be further XML entries.

First, the XML structure for a template is opened using `<PDFTemplate>`, but two parameters are also contained here. `Type="Form"` specifies that the template is created with an Adobe form. `PDFFile="TemplateName.pdf"` defines the form to be used. Enter the name of your previously created PDF form here. The XML structure is closed with `</PDFTemplate>`. You get the following structure:

```
<PDFTemplate Type="Form" PDFFile="Template name.pdf">
  MORE XML CODE
</PDFTemplate>
```

In the middle section, you can now enter additional XML code for assigning the previously defined form fields. To reference the field where the preview or 3D model is to be displayed, add the following entry:

```
<PDFFormField Name="YourFieldName3DModel1" Type="3DWindow"/>
```

Replace the entry `YourFieldName3DModel` with the name you entered for the desired field. The "Type" is defined and can be taken from the table below.

You get the following structure:

```
<PDFTemplate Type="Form" PDFFile="Template name.pdf">
  <PDFFormField Name="YourFieldName3DModell" Type="3DWindow"/>
</PDFTemplate>
```

Text fields can contain static and variable content. In this example, the file name of the exported model is passed to the `Name="Filename"` field with `<Line Text="%file"/>`. You get the following structure:

```
<PDFTemplate Type="Form" PDFFile="Template name.pdf">
  <PDFFormField Name="YourFieldName3DModell" Type="3DWindow"/>
  <PDFFormField Name="Filename" Type="Text">
    <Content>
      <Line Text="%file"/>
    </Content>
  </PDFFormField>
</PDFTemplate>
```

Now add more lines for all required fields and store all files (PDF, XML, JavaScript and graphics) in one of the two PDF template folders:

- Installation directory\Resources\Templates\PDF
- %USERNAME%\Documents\Kisters\ViewStation\Templates\PDF

Your template will be available in the KISTERS 3DViewStation at the next start. The PDF template list is created as a common list from both folders.

Available design elements

3D model

Adobe form field type: Button

XML type: 3DWindow

XML example: `<PDFFormField Name="IhrFeldname3DModell" Type="3DWindow"/>`

Description: For the area in which the preview of the model or, if activated, the 3D model is rendered, the form field **BUTTON** is recommended.

Images/Logos

Adobe form field type: Image field

XML type: Image

XML example: `<PDFFormField Name="CompanyLogo" Type="Image" File="Logo.png"/>`

Description: For embedding graphics.

Text

Adobe form field type: Text field

XML type: Text

XML example: `<PDFFormField Name="IhrFeldname3DModell" Type="3DWindow"/>`

Description: In addition to static text, dynamic text can also be passed to a text field using the following variables.

- %user = Username
- %file = File name
- %date = Current date
- %time = Current time

Carousel view

Adobe form field type: Text field and button

XML type: ViewList

XML example: `<PDFFormField Name="ViewList" Type="ViewList"/>`

Description: The carousel view consists of three individual elements:

- The text field that displays three thumbnails horizontally.
- The **[BACK]** button.
Form name: ButScrollViewsUP
- The **[NEXT]** button.
Form name: ButScrollViewsDOWN

Bill of material

Adobe form field type: Selection list

XML type: PartList

XML example: `<PDFFormField Name="PartList" Type="PartList"/>`

Description: Scrollable bill of material of all parts. The parts can be selected via the bill of material.

JavaScript

Adobe form field type: Button

XML type: MyActionButton

XML example:

Description: For more information, please read the section "Embedding JavaScript in 3D PDF".

Embed JavaScript in 3D PDF

In order to extend the functionality of the 3D PDF templates, JavaScript can be embedded. Three variants are available. The JavaScript file is placed in the above-mentioned user or installation directory of the template (like other dependencies too). You will also find the following three examples in the installation directory:

- Execute JavaScript when opening the 3D PDF (e.g.: JavaScriptDocument.js).
- Execute JavaScript when activating the 3D scene (e.g.: JavaScript3DArtwork.js).
- Execute JavaScript by activating an inserted button (see MyActionButton above) (e.g.: JavaScriptButton.js).

3.5 Print

Use the **PRINT** function in the **START** tab to print the model area directly from within 3DViewStation.

The **PRINT** dialog offers the option of adding a header and footer with title, date, author and other information. Enter the desired information in the relevant fields or use the preconfigured variables like "%FILE" to insert the relevant file name. The variables can be inserted at the cursor position via the drop-down menu **ADD VARIABLE**. The font and font size can be changed via the **FONT** button.

You will furthermore find visualization and relevant preview settings in the pane area on the right.

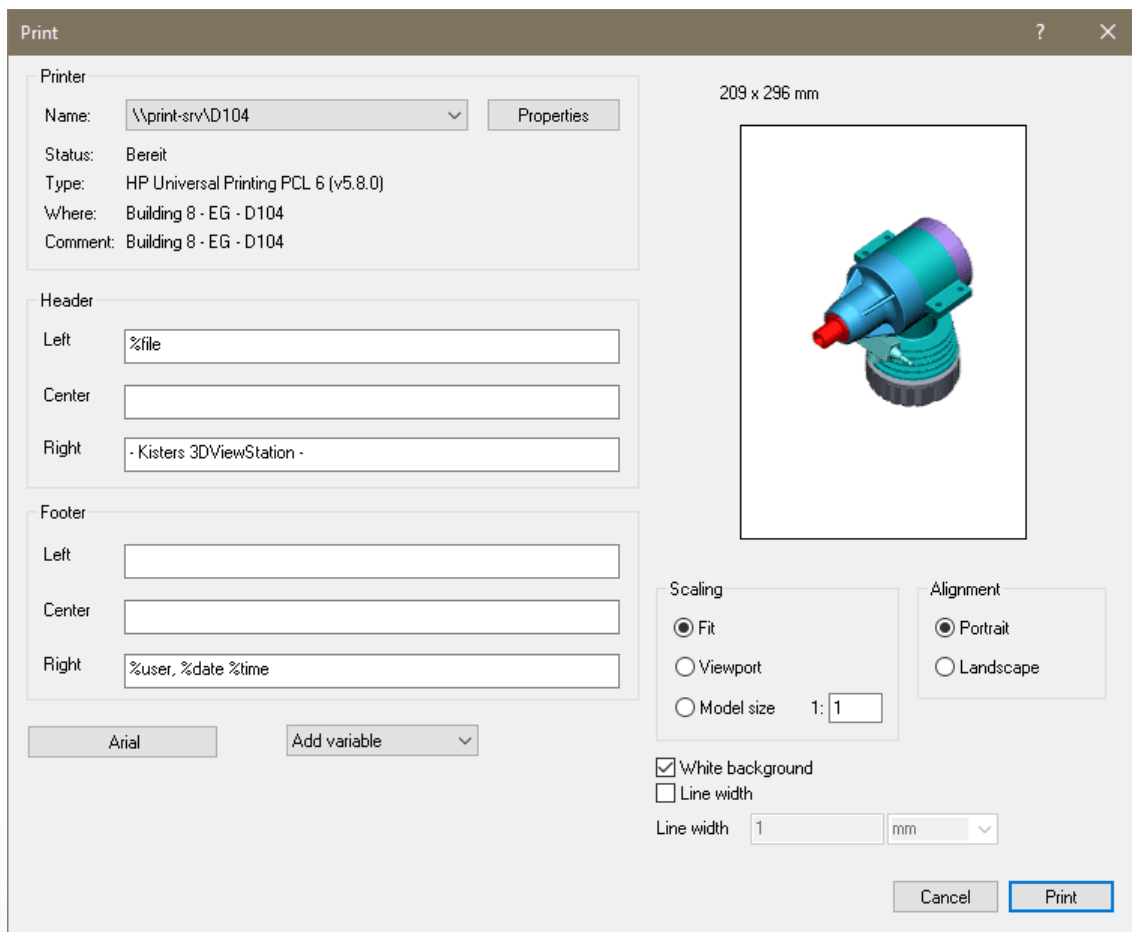



Chapter IV:

Miscellaneous

4 Miscellaneous

This chapter contains these topics:

- [3Dconnexion 3D Mouse](#) 

4.1 3Dconnexion 3D Mouse

3DViewStation supports 3Dconnexion 3D mouse versions. Please install the driver software in accordance with the 3Dconnexion manufacturer instructions and connect the 3D mouse. Open the KISTERS 3DViewStation after its successful installation. The 3D mouse will be detected and activated automatically. You can also continue to use your standard mouse in parallel.

Images and menu navigation for your 3D mouse may differ from our description depending on the model and software version.

The 3D mouse will allow you to modify the camera view of the 3D model in all 6 degrees of freedom. Hold the controls of your 3D mouse as if you were holding the actual model in your hand. The movements of your hand are translated into model movements. You can adjust the motion speed of the mouse movements via the 3Dconnexion manufacturer software if the mouse movement feels too fast or too slow.

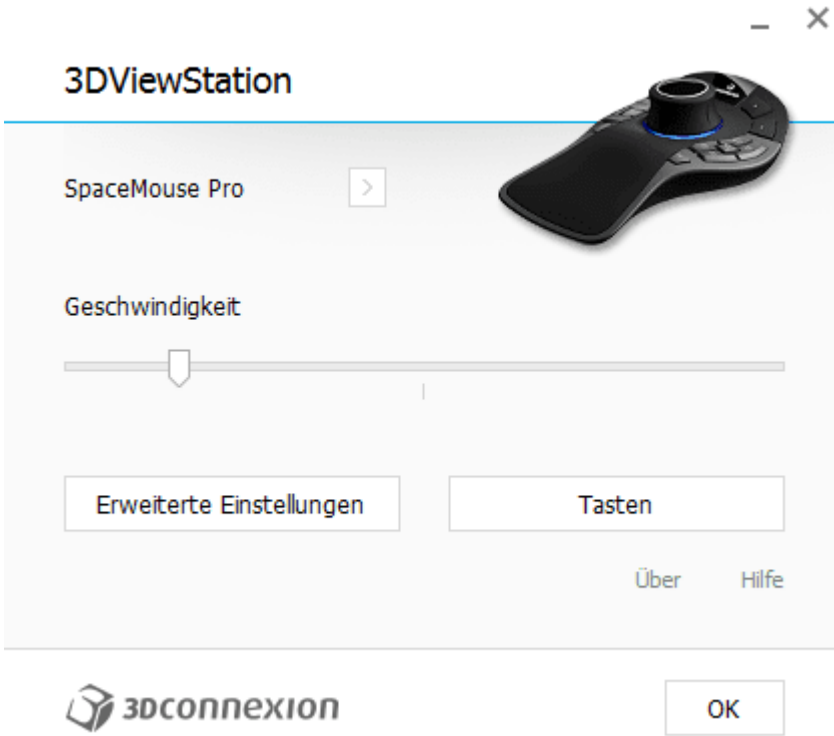
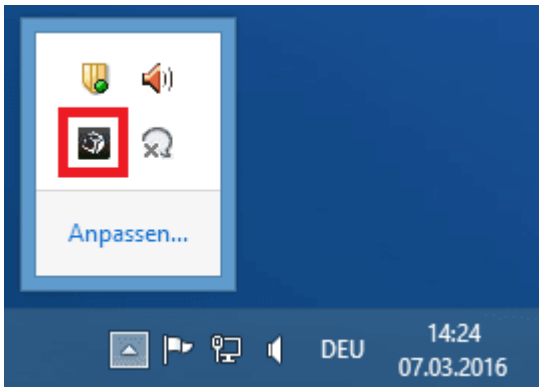



Erweiterte Einstellungen

3DViewStation

Navigation		Geschwindigkeit			
<input checked="" type="checkbox"/>	Bewegen / Zoomen				
<input checked="" type="checkbox"/>	Rotation				
<input type="checkbox"/>	Dominant				
Zoom-Richtung					
<input checked="" type="radio"/>	Vorwärts / Rückwärts				
<input type="radio"/>	Hoch / Runter				
			<input checked="" type="checkbox"/>		<input type="checkbox"/>
			<input checked="" type="checkbox"/>		<input type="checkbox"/>
			<input checked="" type="checkbox"/>		<input type="checkbox"/>
			<input checked="" type="checkbox"/>		<input type="checkbox"/>
			<input checked="" type="checkbox"/>		<input type="checkbox"/>
			<input checked="" type="checkbox"/>		<input type="checkbox"/>
			<input checked="" type="checkbox"/>		<input type="checkbox"/>



Standardeinstellungen

Schließen

Right click [**FIT**] to adjust the view to the model until it is completely visible again. Left click [**MENU**] to access the 3D mouse configuration menu (above, image in the middle). You can additionally adjust the key assignment configuration. Click **BUTTONS** to make your changes (above, image in the middle).

Key configuration

- X

Tasten
3DViewStation

SpaceMouse Pro >

1	Virtual NumPad >	MENU	Eigenschaften... >	ESC	Esc >
2	RM Pro >	FIT	Fit >	CTRL	STRG >
3	Rückgängig >	ROT	Rotation An/Aus >	ALT	Alt >
4	Wiederholen >			SHIFT	Shift >
				T	Draufsicht >
				R	Rechte Seitenansicht >
				F	Vorderansicht >
				ROL+	Rollen + >



 StandardEinstellungen Schließen